

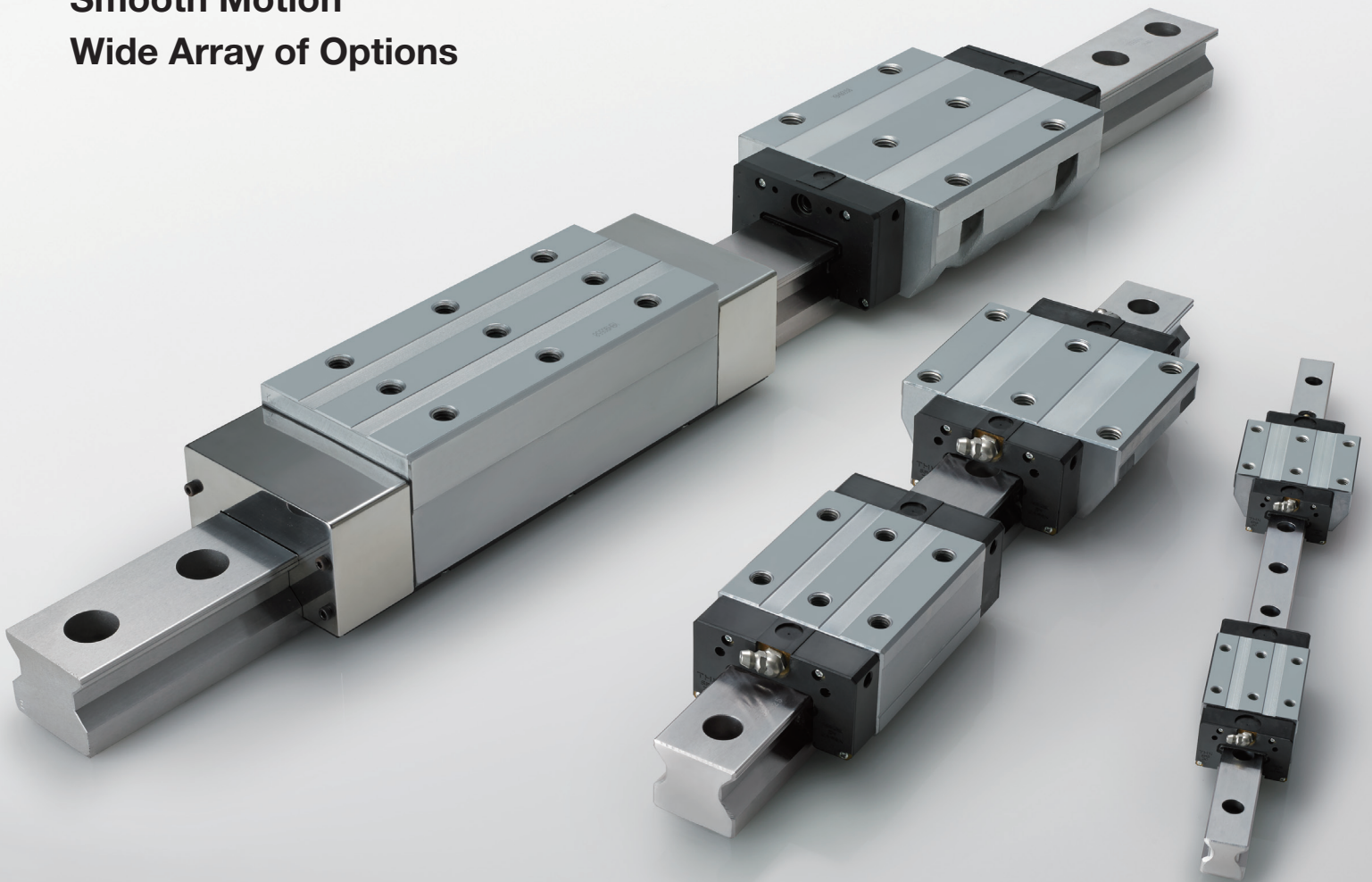

Caged Roller LM Guide

SRG/SRN

Ultra-high Rigidity
Long-term Maintenance-free Operation
Smooth Motion
Wide Array of Options



For details, visit THK at www.thk.com

*Product information is updated regularly on the THK website.

Roller Cage Effect

According to the history of rotary ball bearings, which used balls as the rolling elements, their early forms were full-ball types without ball cages.

Therefore, friction between balls caused loud noise, made high-speed rotation impossible and shortened the service life.

Twenty years later, a Caged Ball design was developed for ball bearings. The new design enabled high-speed rotation at a low noise level, and extended the service life despite a reduced number of balls used. It marked a major development of ball bearings.

Similarly, the performance of needle bearings using rollers was significantly improved by the caged roller structure, as represented in the history of bearings. The Cage Roller LM Guide has a structure that does not cause friction between rollers and allows grease to be retained in a grease pocket between adjacent rollers, thus ensuring long-term maintenance-free operation.

- Long-term Maintenance-free Operation
- High-Speed Operation
- Low Noise, Acceptable Running Sound
- Smooth Motion

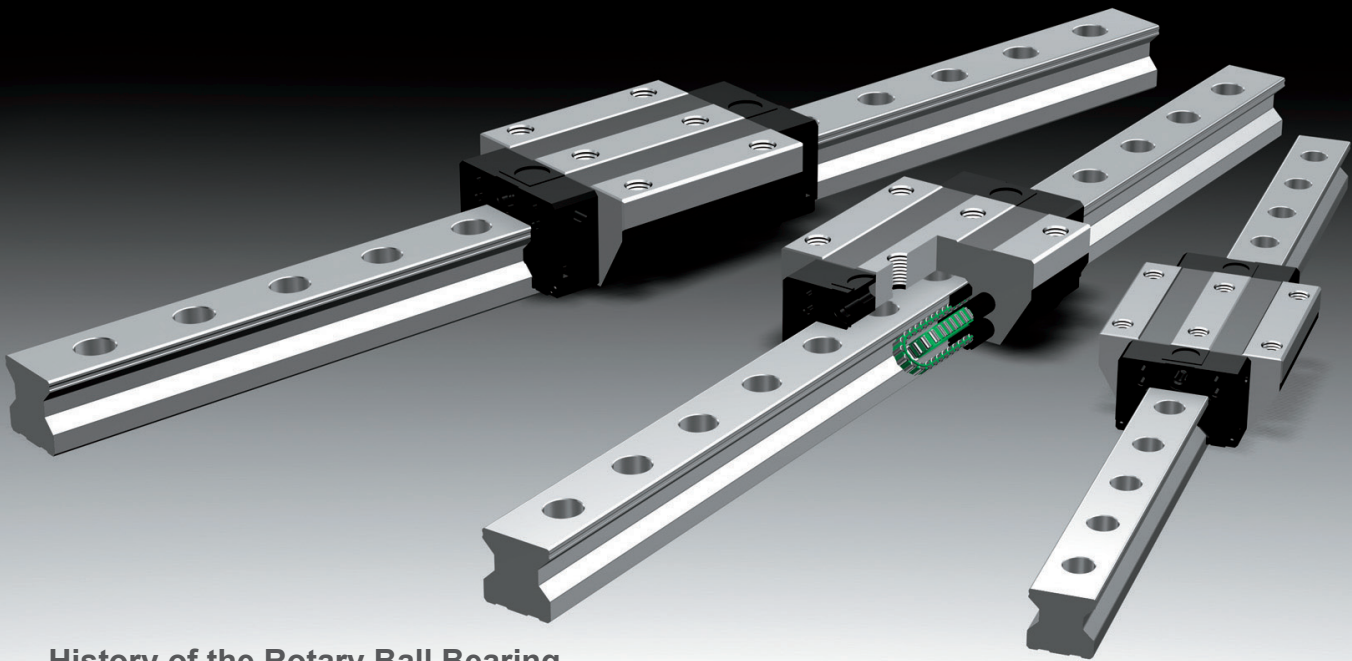

History of the Rotary Ball Bearing

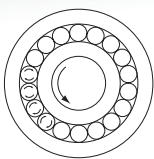

Conventional Structure

- Adjacent balls make point contact each other. As a result, unit surface pressure is high, the oil film easily breaks, and wear occurs due to friction.
- The service life becomes shorter.

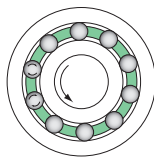

Caged Ball Structure

- The service life is prolonged due to the elimination of wear caused by friction between balls.
- The absence of friction between balls results in reduced heat generation during high-speed rotation.
- The absence of friction between balls eliminates collision noise of the balls.
- Even spacing of the balls enables them to move smoothly.
- Retention of lubricant in the ball cage ensures a long service life.

Caged Roller LM Guide

With the Caged Roller LM Guide, the use of a roller cage allows lines of evenly spaced rollers to circulate, thus to reduce fluctuations in rolling resistance and achieve smooth and stable motion. In addition, grease held in a space between the roller circulation path and the roller cage (grease pocket) is applied on the contact surface between each roller and the roller cage as the roller rotates, forming an oil film on the roller surface. This minimizes the risk of oil-film break.

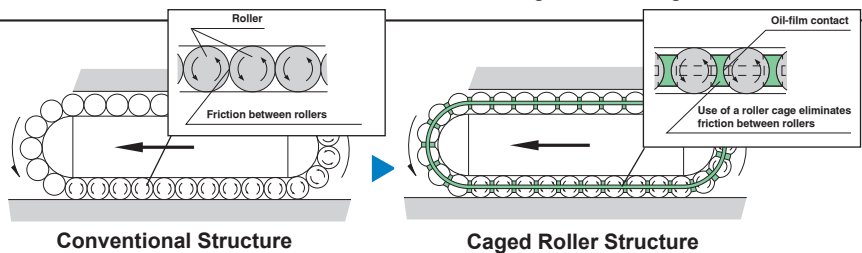

Ultra-high Rigidity Caged Roller LM Guide

SRG/SRN

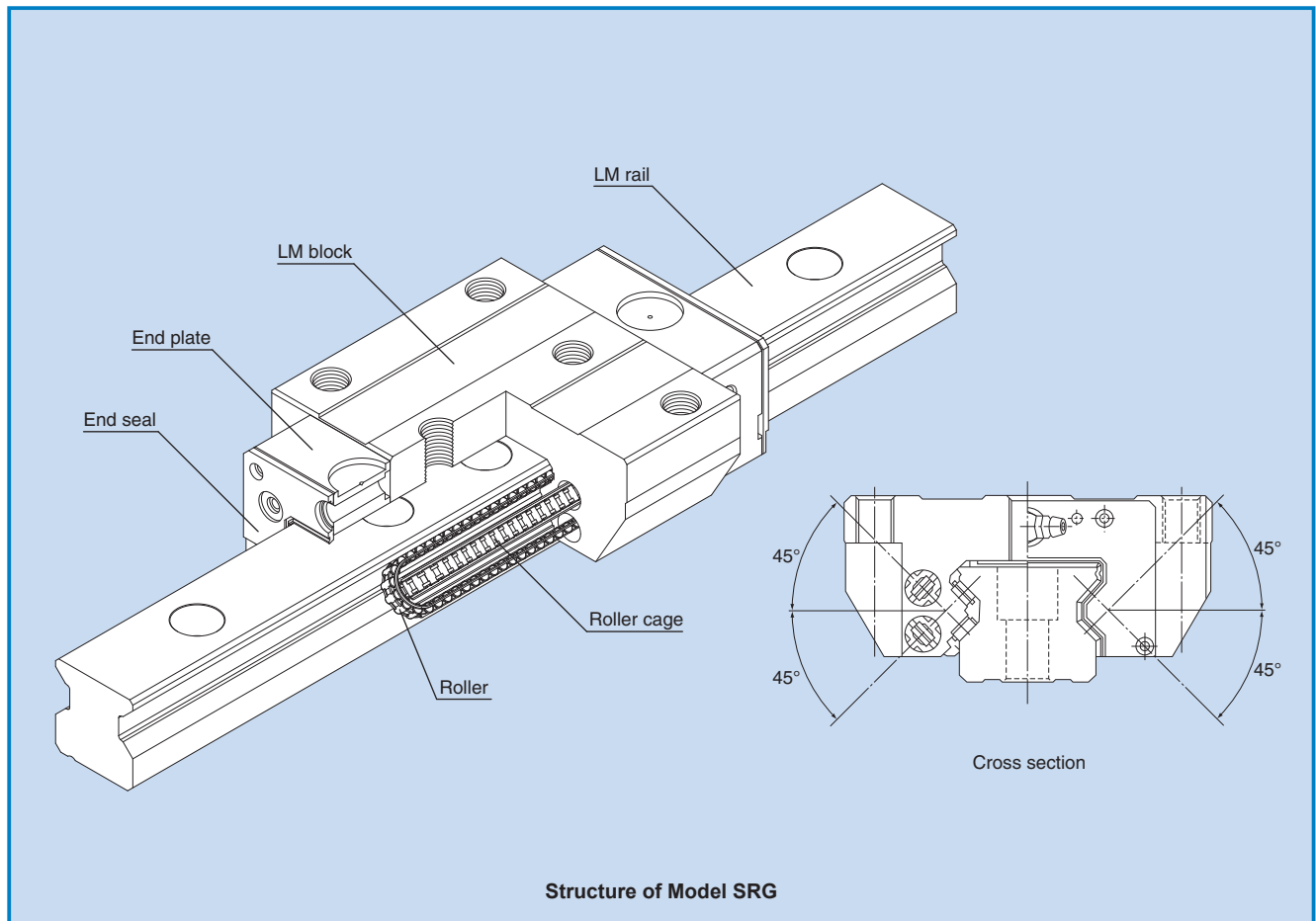

Models SRG and SRN are ultra-high rigidity Roller Guides that use roller cages to allow low-friction, smooth motion and achieve long-term maintenance-free operation.

- **Ultra-high Rigidity**

They achieve remarkably high rigidity by using rollers, which are less subject to deformation, for the rolling elements and having the overall roller length 1.5 times greater than the roller diameter.

- **4-way Equal Load**

Each row of balls is placed at a contact angle of 45° so that the rated loads applied to the LM block are uniform in the four directions (radial, reverse radial and lateral directions), ensuring high rigidity in any direction.

- **Global Standard Size[SRG]**

SRG is designed to have dimensions almost the same as that of the full-ball type LM Guide model HSR, which THK as a pioneer of the linear motion system has developed and is a de facto global standard model.

- **Low-Profile Low Center of Gravity[SRN]**

Because it has a lower total height than the Caged Roller LM Guide Model SRG, it is ideal for compact designs.

• High Rigidity Evaluation Data

Remarkably high rigidity is achieved by using rollers, which are less subject to deformation, for the rolling elements and having the overall roller length 1.5 times greater than the roller diameter.

[Magnitude of the preload]

SRG: radial clearance C0

Conventional type: equivalent to radial clearance C0

Radial rigidity

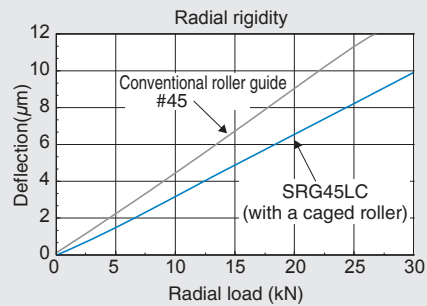
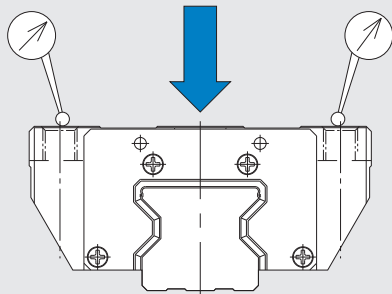

Reverse-radial rigidity

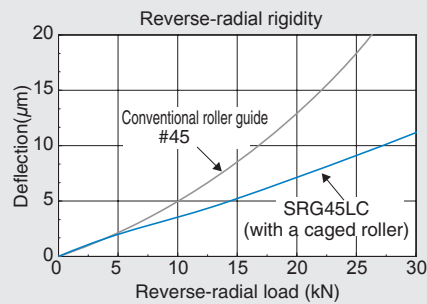
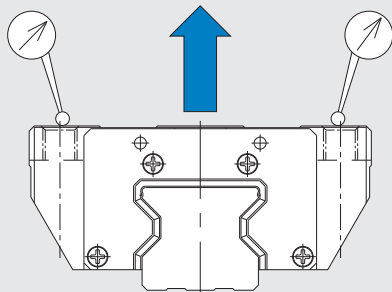

Horizontal rigidity

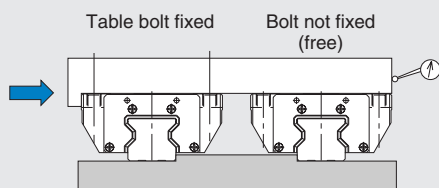

Place two rails in parallel to each other so that a moment is not applied, and measure the rigidity with one rail not fixed with bolts.

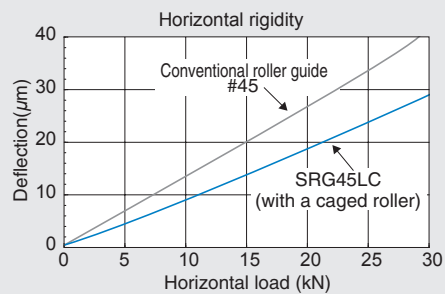

• Smoothness Evaluation Data

The roller cage allows rollers to be uniformly aligned as they circulate. As a result, fluctuation of the rolling resistance is minimized, and stable, smooth motion is achieved.

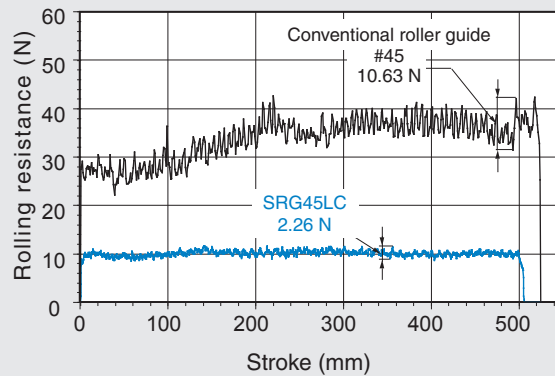

Result of Measuring Rolling Resistance Fluctuation

Conditions: Feed speed: 10 mm/s
Applied load: no load (1 block)

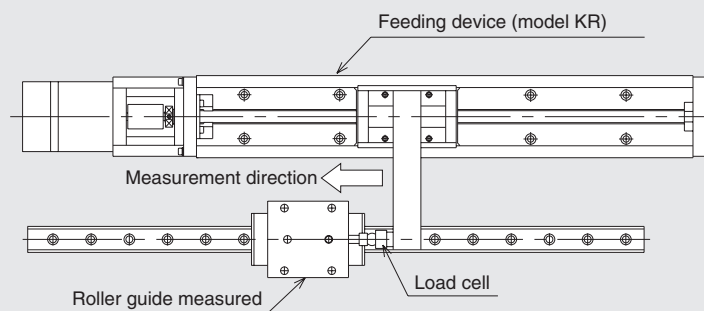

Rolling Resistance Measuring Equipment

• High durability Evaluation Data

Use of roller cages eliminates friction between rollers, reduces heat generation and increases grease retention, enabling long-term maintenance-free operation to be achieved.

Tested model: SRG45LC
Conditions: preload: clearance C0
Speed: 180 m/min
Acceleration: 1.5 G
Stroke: 2,300 mm
Lubrication: initial grease lubrication only (THK AFB-LF Grease)

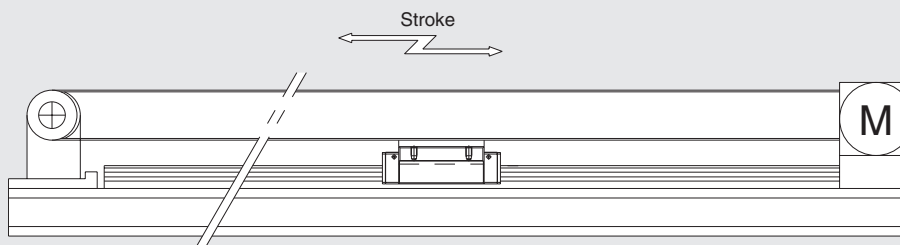

Test result: after running 15,000 km, no anomaly

Result of High Speed Durability Test

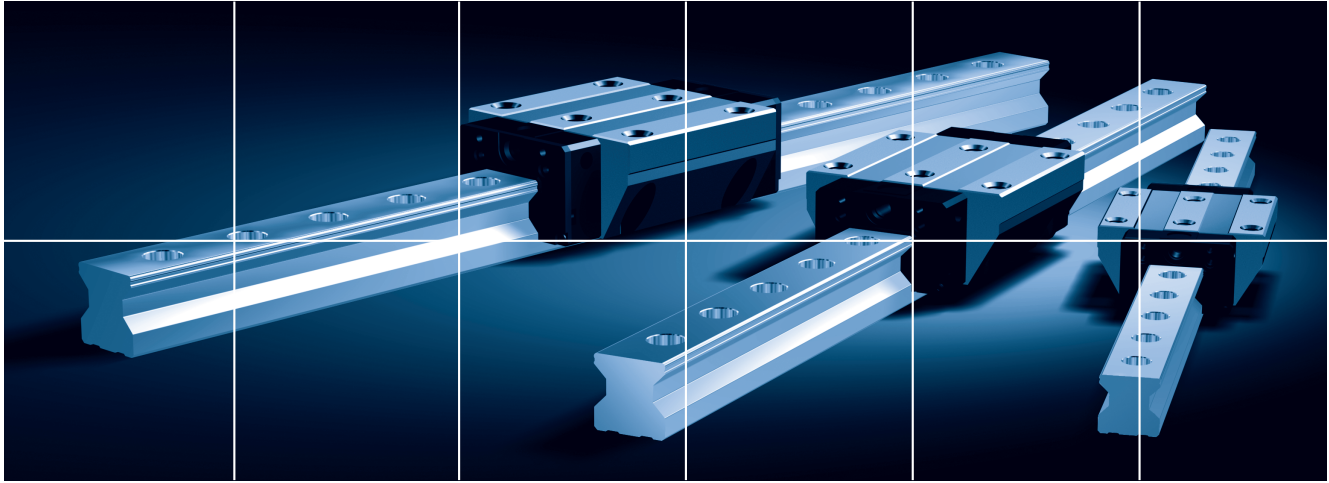

SRG/SRN Outline

Models SRG/SRN - Product Overview

Having almost the same dimensions as the de facto standard, full-ball type LM Guide model HSR, these models are superbly capable of receiving an ultra-super heavy load and optimal for machine tools.

Major applications machining center / NC lathe / grinding machine / five axis milling machine / drilling machine / NC milling machine / semiconductor manufacturing machine / molding machine

Model SRG-A SRG-C

The flange of the LM block has tapped holes. Model SRG-A can be mounted from the top, and model SRG-C can be mounted from the top or the bottom.

- SRG 15A •SRG 35C
- SRG 20A •SRG 45C
- SRG 25C •SRG 55C
- SRG 30C •SRG 65C

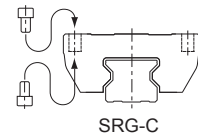
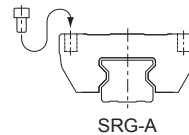
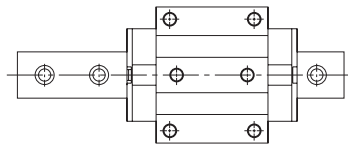

Model SRG-LA SRG-LC

The LM block has the same sectional shape as model SRG-A, SRG-C, but has a longer overall LM block length (L) and a greater rated load.

- SRG 20LA •SRG 55LC
- SRG 25LC •SRG 65LC
- SRG 30LC •SRG 85LC
- SRG 35LC •SRG 100LC
- SRG 45LC

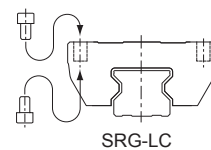
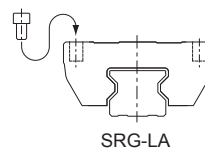
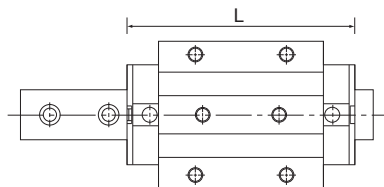

Model SRG-SLC

The LM block has the same cross-sectional shape as model SRG-LC, but has a longer overall LM block length (L) and a greater rated load.

- SRG 35SLC •SRG 55SLC
- SRG 45SLC •SRG 65SLC

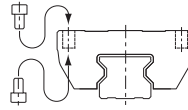
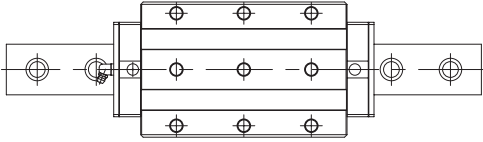

Model SRG-V SRG-R

The LM block has a smaller width (W) and is equipped with tapped holes. Used in places where space for table width is limited.

- SRG 15V •SRG 35R
- SRG 20V •SRG 45R
- SRG 25R •SRG 55R
- SRG 30R •SRG 65V

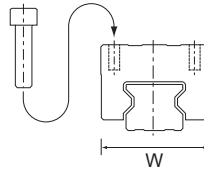
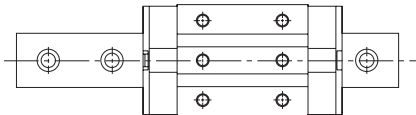

Model SRG-LV SRG-LR

The LM block has the same sectional shape as model SRG-V, SRG-R, but has a longer overall LM block length (L) and a greater rated load.

- SRG 20LV •SRG 45LR
- SRG 25LR •SRG 55LR
- SRG 30LR •SRG 65LV
- SRG 35LR

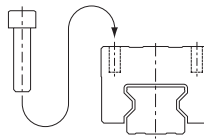
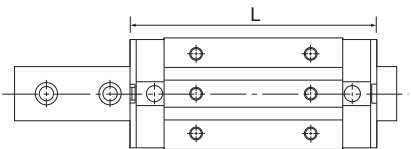

Model SRG-SLV SRG-SLR

The LM block has the same cross-sectional shape as model SRG-LR, but has a longer overall LM block length (L) and a greater rated load.

- SRG 35SLR •SRG 55SLR
- SRG 45SLR •SRG 65SLV

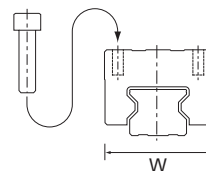
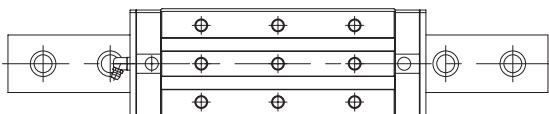

Build-to-order Models

Model SRN-C

The flange of the LM block has tapped holes.
Can be mounted from the top or bottom.
Used in places where the table cannot have through holes for mounting bolts.

- SRN 35C
- SRN 45C
- SRN 55C

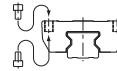
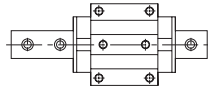

Model SRN-LC

The LM block has the same sectional shape as model SRN-C, but has a longer overall LM block length (L) and a greater rated load.

- SRN 35LC
- SRN 45LC
- SRN 55LC
- SRN 65LC

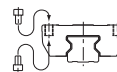
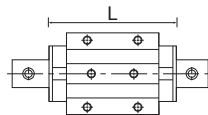

Model SRN-R

The LM block has a smaller width (W) and is equipped with tapped holes.
Used in places where space for table width is limited.

- SRN 35R
- SRN 45R
- SRN 55R

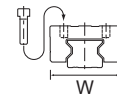

Model SRN-LR

The LM block has the same sectional shape as model SRN-R, but has a longer overall LM block length (L) and a greater rated load.

- SRN 35LR
- SRN 45LR
- SRN 55LR
- SRN 65LR

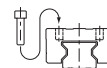
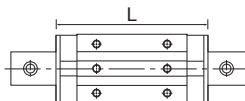

*1: Models SRG/SRN dimensional tables

Model SRG-A/LA/C/LC: starting on P. 13

Model SRG-V/LV/R/LR: starting on P. 17

Model SRN-C/LC: starting on P. 21

Model SRN-R/LR: starting on P. 23

Rated Loads in All Directions

Models SRG/SRN are capable of receiving loads in all four directions: radial, reverse-radial and lateral directions.

The basic load ratings are uniform in the four directions (radial, reverse-radial and lateral directions), and their actual values are provided in the dimensional table*1 for models SRG/SRN.

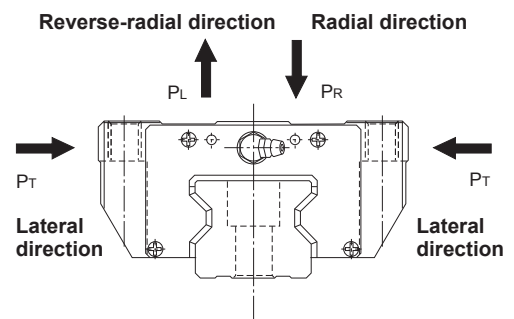

Equivalent Load

When the LM block of models SRG/SRN receives loads in all directions simultaneously, the equivalent load is obtained from the equation below.

$$P_E = P_R (P_L) + P_T$$

- P_E :Equivalent load (N)
 ·Radial direction
 ·Reverse-radial direction
 ·Lateral direction
- P_R :Radial load (N)
- P_L :Reverse-radial load (N)
- P_T :Lateral load (N)

Service Life

The service life of an LM Guide is subject to slight variations even if multiple units of the identical model manufactured in the same process are used under the same operational conditions. Therefore, it is necessary to use the nominal life defined below as a reference value for obtaining the service life of the LM Guide.

Nominal Life

The nominal life means the total travel distance that 90% of a group of the same LM Guide model can achieve without flaking (scale-like exfoliation on the metal surface) after individually running under the same conditions.

Service Life Time

Once the nominal life (L) has been obtained, the service life time can be obtained using the equation on the right if the stroke length and the number of reciprocations are constant.

$$L = \left(\frac{f_H \cdot f_T \cdot f_C}{f_W} \cdot \frac{C}{P_C} \right)^{\frac{10}{3}} \times 100$$

L	: Nominal life	(km)
C	: Basic dynamic load rating*1	(N)
P _C	: Calculated load	(N)
f _H	: Hardness factor	(see Fig. 1)
f _T	: Temperature factor	
f _C	: Contact factor	(see Table 1)
f _W	: Load factor	(see Table 2)

$$L_h = \frac{L \times 10^6}{2 \times l_s \times n_1 \times 60}$$

L _h	: Service life time	(h)
l _s	: Stroke length	(mm)
n ₁	: No. of reciprocations per min	(min ⁻¹)

*1: Basic dynamic load rating (C)

The basic dynamic load rating (C) indicates the load with constant direction and magnitude, under which the rated life (L) is L = 50 km for an LM system using balls, or L = 100 km for an LM system using rollers, when a group of identical LM system independently operating under the same conditions.

f_H : Hardness factor

To ensure the achievement of the optimum load capacity of the LM Guide, the raceway hardness must be between 58 and 64 HRC. At hardness below this range, the basic dynamic and static load ratings decrease. Therefore, the rating values must be multiplied by the respective hardness factors (f_H). Since the LM Guide has sufficient hardness, the f_H value for the LM Guide is normally 1.0.

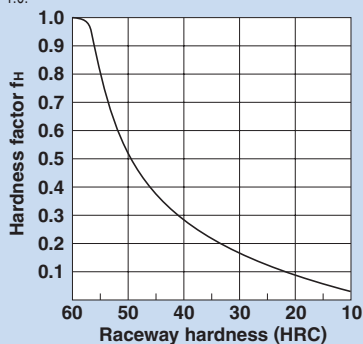

Fig. 1

f_C : Contact factor

When multiple LM blocks are used in close contact with each other, it is difficult to achieve uniform load distribution due to moment loads and mounting-surface accuracy. When using multiple blocks in close contact with each other, multiply the basic load rating (C or C₀) by the corresponding contact factor indicated in Table 1.

Note: When uneven load distribution is expected in a large machine, consider using a contact factor from Table 1.

Table 1 Contact Factor (f_C)

Number of blocks used in close contact	Contact factor f _C
2	0.81
3	0.72
4	0.66
5	0.61
6 or greater	0.6
Normal use	1

f_T : Temperature factor

Since the service temperature of a Caged Roller LM Guide is normally 80°C or below, the temperature factor f_T is 1.0.

f_W : Load factor

In general, reciprocating machines tend to produce vibrations or impact during operation. Additionally, it is especially difficult to accurately determine all vibrations generated during high-speed operation and impacts produced each time the machine starts and stops. Therefore, where the effects of speed and vibration are estimated to be significant, divide the basic dynamic load rating (C) by a load factor selected from Table 2, which contains empirically obtained data.

Table 2 Load Factor (f_W)

Vibration/impact	Speed (V)	f _W
Faint	Very slow V ≤ 0.25m/s	1 to 1.2
Weak	Slow 0.25 < V ≤ 1m/s	1.2 to 1.5
Medium	Medium 1 < V ≤ 2m/s	1.5 to 2
Strong	Fast V > 2m/s	2 to 3.5

***1: Preload**

Preload is an internal load applied to the rolling elements (roller) in advance in order to increase the rigidity of the LM block. The clearances of all SRG/SRN models are adjusted to specified values before shipment, and therefore it is unnecessary to adjust their preloads.

Radial Clearance Standard

Since the radial clearance of an LM Guide greatly affects the running accuracy, load carrying capacity and rigidity of the LM Guide, it is important to select an appropriate clearance according to the application.

In general, selecting a negative clearance (i.e., a preload*1 is applied) while taking into account possible vibrations and impact generated from reciprocating motion favorably affects the service life and the accuracy.

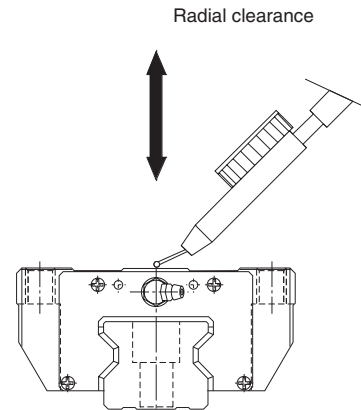

Radial clearance of models SRG/SRN

Unit: μm

Model No.	Indication symbol	Normal	Light preload	Medium preload
	No symbol	C1	C0	
15		- 0.5 to 0	- 1 to - 0.5	- 2 to - 1
20		- 0.8 to 0	- 2 to - 0.8	- 3 to - 2
25		- 2 to - 1	- 3 to - 2	- 4 to - 3
30		- 2 to - 1	- 3 to - 2	- 4 to - 3
35		- 2 to - 1	- 3 to - 2	- 5 to - 3
45		- 2 to - 1	- 3 to - 2	- 5 to - 3
55		- 2 to - 1	- 4 to - 2	- 6 to - 4
65		- 3 to - 1	- 5 to - 3	- 8 to - 5
85		- 3 to - 1	- 7 to - 3	- 12 to - 7
100		- 3 to - 1	- 8 to - 3	- 13 to - 8

Accuracy Standard

Accuracies of models SRG/SRN are specified in terms of running parallelism^{*2}, dimensional tolerance for height and width, and height and width difference between a pair^{*3,4} when 2 or more LM blocks are used on one rail or when 2 or more rails are mounted on the same plane.

Accuracies of models SRG/SRN are categorized into High-accuracy grade* (H), Precision grade (P), Super precision grade (SP) and Ultra precision grade (UP) as indicated in the table below.

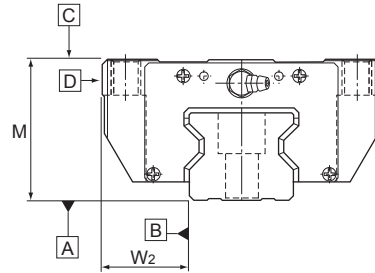

Unit: mm

Model No.	Accuracy standard Item	High-accuracy grade*	Precision grade	Super precision grade	Ultra precision grade	
		H*	P	SP	UP	
15 20	Dimensional tolerance for height M	—	$\begin{matrix} 0 \\ -0.03 \end{matrix}$	$\begin{matrix} 0 \\ -0.015 \end{matrix}$	$\begin{matrix} 0 \\ -0.008 \end{matrix}$	
	Difference in height M	—	0.006	0.004	0.003	
	Dimensional tolerance for width W ₂	—	$\begin{matrix} 0 \\ -0.02 \end{matrix}$	$\begin{matrix} 0 \\ -0.015 \end{matrix}$	$\begin{matrix} 0 \\ -0.008 \end{matrix}$	
	Difference in width W ₂	—	0.006	0.004	0.003	
	Running parallelism of surface [C] against surface [A]	—	as shown in the table below			
	Running parallelism of surface [D] against surface [B]	—	as shown in the table below			
25 30 35	Dimensional tolerance for height M	±0.04	$\begin{matrix} 0 \\ -0.04 \end{matrix}$	$\begin{matrix} 0 \\ -0.02 \end{matrix}$	$\begin{matrix} 0 \\ -0.01 \end{matrix}$	
	Difference in height M	0.015	0.007	0.005	0.003	
	Dimensional tolerance for width W ₂	±0.03	$\begin{matrix} 0 \\ -0.03 \end{matrix}$	$\begin{matrix} 0 \\ -0.015 \end{matrix}$	$\begin{matrix} 0 \\ -0.01 \end{matrix}$	
	Difference in width W ₂	0.015	0.007	0.005	0.003	
	Running parallelism of surface [C] against surface [A]	—	as shown in the table below			
	Running parallelism of surface [D] against surface [B]	—	as shown in the table below			
45 55	Dimensional tolerance for height M	±0.04	$\begin{matrix} 0 \\ -0.05 \end{matrix}$	$\begin{matrix} 0 \\ -0.03 \end{matrix}$	$\begin{matrix} 0 \\ -0.015 \end{matrix}$	
	Difference in height M	0.015	0.007	0.005	0.003	
	Dimensional tolerance for width W ₂	±0.04	$\begin{matrix} 0 \\ -0.04 \end{matrix}$	$\begin{matrix} 0 \\ -0.025 \end{matrix}$	$\begin{matrix} 0 \\ -0.015 \end{matrix}$	
	Difference in width W ₂	0.015	0.007	0.005	0.003	
	Running parallelism of surface [C] against surface [A]	—	as shown in the table below			
	Running parallelism of surface [D] against surface [B]	—	as shown in the table below			
65 85 100	Dimensional tolerance for height M	±0.04	$\begin{matrix} 0 \\ -0.05 \end{matrix}$	$\begin{matrix} 0 \\ -0.04 \end{matrix}$	$\begin{matrix} 0 \\ -0.03 \end{matrix}$	
	Difference in height M	0.02	0.01	0.007	0.005	
	Dimensional tolerance for width W ₂	±0.04	$\begin{matrix} 0 \\ -0.05 \end{matrix}$	$\begin{matrix} 0 \\ -0.04 \end{matrix}$	$\begin{matrix} 0 \\ -0.03 \end{matrix}$	
	Difference in width W ₂	0.02	0.01	0.007	0.005	
	Running parallelism of surface [C] against surface [A]	—	as shown in the table below			
	Running parallelism of surface [D] against surface [B]	—	as shown in the table below			

***2: Running parallelism**

It refers to a parallelism error between the LM block and the LM rail datum plane when the LM block travels the whole length of the LM rail, which is secured on the reference datum plane using bolts.

***3: Difference in height M**

It indicates a difference between the minimum and maximum values in height (M) of each of the LM blocks used on the same plane in combination.

***4: Difference in width W₂**

It indicates a difference between the minimum and maximum values in width (W₂) between each of the LM blocks, mounted on one LM rail in combination, and the LM rail.

LM Rail Length and Running Parallelism for Models SRG/SRN

Unit: μm

LM rail length (mm)		Running Parallelism Values			
Above	Or less	High-accuracy grade*	Precision grade	Super precision grade	Ultra precision grade
		H*	P	SP	UP
—	50	3	2	1.5	1
50	80	3	2	1.5	1
80	125	3	2	1.5	1
125	200	3.5	2	1.5	1
200	250	4	2.5	1.5	1
250	315	4.5	3	1.5	1
315	400	5	3.5	2	1.5
400	500	6	4.5	2.5	1.5
500	630	7	5	3	2
630	800	8.5	6	3.5	2
800	1000	9	6.5	4	2.5
1000	1250	11	7.5	4.5	3
1250	1600	12	8	5	4
1600	2000	13	8.5	5.5	4.5
2000	2500	14	9.5	6	5
2500	3090	16	11	6.5	5.5

*For model SRG, sizes 35 to 65 are only available in High accuracy grade (H) or above, other sizes are only available in Precision grade (P) or above. For model SRN, all sizes are only available in Precision grade (P) or above.

Shoulder Height of the Mounting Base and the Corner Radius

Normally, the mounting base for the LM rail and the LM block has a datum plane on the side face of the shoulder of the base in order to allow easy installation and highly accurate positioning.

The corner of the mounting shoulder must be machined to have a recess, or machined to be smaller than the corner radius, to prevent interference with the chamfer of the LM rail or the LM block.

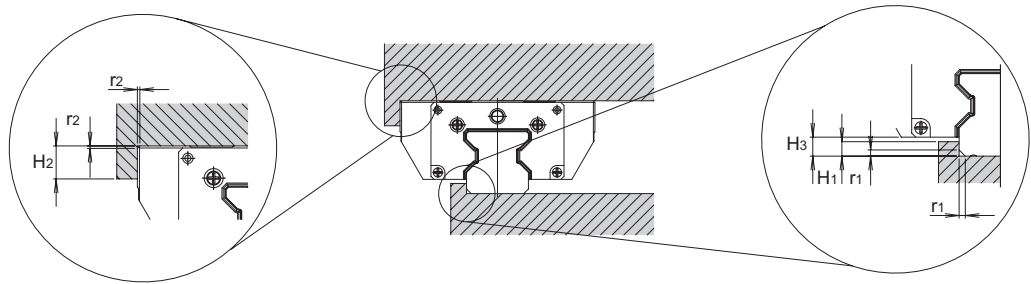

Model SRG

Unit: mm

Model No.	Corner radius for the LM rail r_1 (max)	Corner radius for the LM block r_2 (max)	Shoulder height for the LM rail H_1	Shoulder height for the LM block H_2	H_3
15	0.5	0.5	2.5	4	4
20	0.5	0.5	3.5	5	4.6
25	1	1	4	5	4.5
30	1	1	4.5	5	5
35	1	1	5	6	6
45	1.5	1.5	6	8	8
55	1.5	1.5	8	10	10
65	1.5	2	9	10	11.5
85	1.5	1.5	12	14	16
100	2	2	12	16	16

Model SRN

Unit: mm

Model No.	Corner radius for the LM rail r_1 (max)	Corner radius for the LM block r_2 (max)	Shoulder height for the LM rail H_1	Shoulder height for the LM block H_2	H_3
35	1	1	5	6	6
45	1.5	1.5	6	8	7
55	1.5	1.5	8	10	10
65	1.5	2	8	10	10

For H_1 and H_3 dimensions when the side scraper or protector is attached, please see the below table.

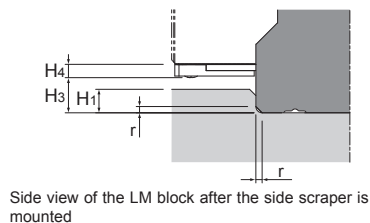

Unit: mm

Model No.	Corner radius r (max)	Shoulder height of the LM rail H_1	H_3	Side scraper thickness H_4	
SRG	35	1	3	4	2
	45	1	3.5	5.5	2.5
	55	1.5	5.5	7.5	2.5
	65	1.5	6	8.5	3

Error Allowance on the Mounting Surface

With Caged Roller LM Guide models SRG/SRN, the rollers serving as the rolling elements ensure high rigidity and the roller retainer prevents rollers from skewing. However, the mounting surface needs to be machined with high precision. A large accuracy error of the mounting surface affects the rolling resistance and the service life. The following shows the maximum error allowance (limit value) of the mounting surface according to the radial clearance.

Error Allowance in Parallelism (P) between Two Rails

Unit: mm

Radial clearance	Normal	C1	C0
Model No.			
SRG 15	0.005	0.003	0.003
SRG 20	0.008	0.006	0.004
SRG 25	0.009	0.007	0.005
SRG 30	0.011	0.008	0.006
SRG/SRN 35	0.014	0.010	0.007
SRG/SRN 45	0.017	0.013	0.009
SRG/SRN 55	0.021	0.014	0.011
SRG/SRN 65	0.027	0.018	0.014
SRG 85	0.040	0.027	0.021
SRG 100	0.045	0.031	0.024

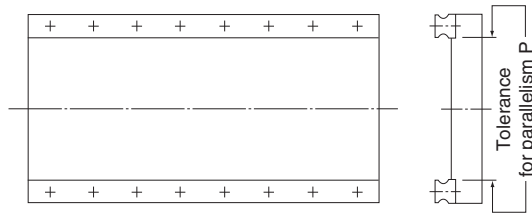

Error Allowance in Vertical Level (X) between Two Rails

Unit: mm

Radial clearance	Normal	C1	C0
Error allowance on the mounting surface (X)	0.00030a	0.00021a	0.00011a

$X = X_1 + X_2$ X_1 : Level difference on the rail mounting surface
 X_2 : Level difference on the block mounting surface

Example of calculation

When the rail span: $a = 500$ mm

Error allowance on the mounting surface:

$$X = 0.0003 \times 500 = 0.15$$

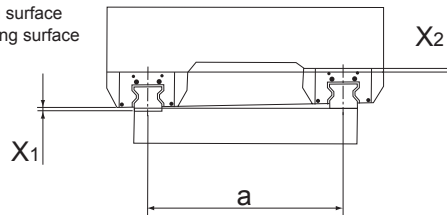

Error Allowance in Level (Y) in the Axial Direction

Unit: mm

Permissible error on the mounting surface	0.000036b
---	-----------

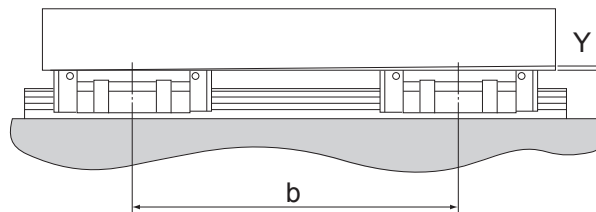

Models SRG-A/C and LA/LC (15-30)

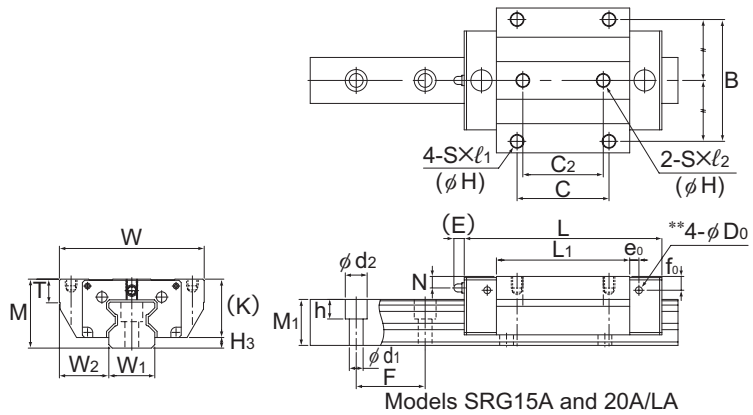
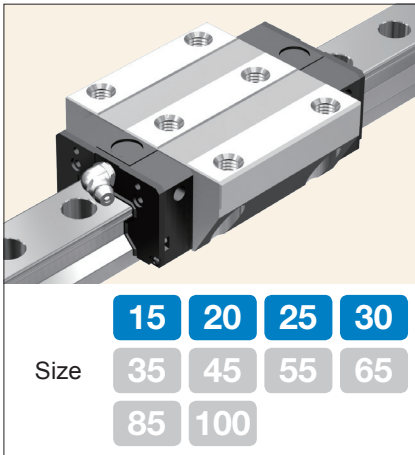

Model No.	Outer dimensions			LM block dimensions																	Grease nipple
	Height	Width	Length	B	C	C ₂	S	H	l ₁	l ₂	L ₁	T	T ₁	K	N	E	e ₀	f ₀	D ₀		
	M	W	L																		
SRG 15A	24	47	69.2	38	30	26	M5	(4.3)	8	7.5	45	7	(8)	20	4	4.5	4	6	2.9	PB107	
SRG 20A SRG 20LA	30	63	86.2 106.2	53	40	35	M6	(5.4)	10	9	58 78	10	(10)	25.4	5	4.5	4	6	2.9	PB107	
SRG 25C SRG 25LC	36	70	95.5 115.1	57	45	40	M8	6.8	—	—	65.5 85.1	9.5	10	31.5	5.5	12	6	6.4	5.2	B-M6F	
SRG 30C SRG 30LC	42	90	111 135	72	52	44	M10	8.5	—	—	75 99	12	14	37	6.5	12	6	7.5	5.2	B-M6F	

Model number coding

SRG30	LC	2	QZ	TTHH	C0	+1200L	P	Z	T	-II
Model number	Type of LM block	No. of LM blocks used on the same rail	With QZ Lubricator	Contamination protection accessory symbol	Radial clearance symbol Normal (No symbol) Light preload (C1) Medium preload (C0)	LM rail length (in mm)	With plate cover	Accuracy symbol High-accuracy grade (H) Precision grade (P)/Super precision grade (SP) Ultra precision grade (UP)	Symbol for LM rail jointed use	Symbol for No. of rails used on the same plane

Note) This model number indicates that a single-rail unit constitutes one set. (i.e., required number of sets when 2 rails are used in parallel is 2 at a minimum.) Those models equipped with QZ Lubricator cannot have a grease nipple. When desiring a grease nipple for a model attached with QZ, contact THK.

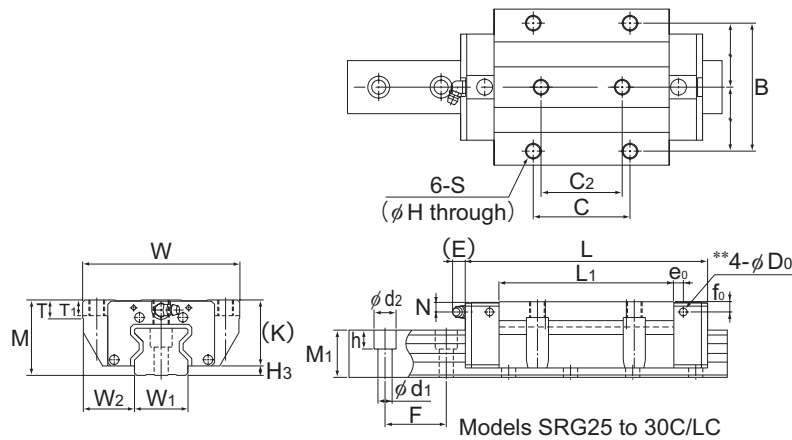

Unit: mm

	LM rail dimensions							Basic load rating		Static permissible moment kN-m*					Mass	
	Width W ₁ 0 -0.05	Height W ₂	Pitch M ₁	Pitch F	Length* d ₁ ×d ₂ ×h	Length* Max	C kN	C ₀ kN	M _A		M _B		M _C	LM block	LM rail	
									1 block	Double blocks	1 block	Double blocks	1 block	kg	kg/m	
4	15	16	15.5	30	4.5×7.5×5.3	3000	11.3	25.8	0.21	1.24	0.21	1.24	0.24	0.20	1.58	
4.6	20	21.5	20	30	6×9.5×8.5	3000	21 26.7	46.9 63.8	0.48 0.88	2.74 4.49	0.48 0.88	2.74 4.49	0.58 0.79	0.42 0.57	2.58	
4.5	23	23.5	23	30	7×11×9	3000	27.9 34.2	57.5 75	0.641 1.07	3.7 5.74	0.641 1.07	3.7 5.74	0.795 1.03	0.7 0.9	3.6	
5	28	31	26	40	9×14×12	3000	39.3 48.3	82.5 108	1.02 1.76	6.21 9.73	1.02 1.76	6.21 9.73	1.47 1.92	1.2 1.6	4.4	

Note) - The maximum length indicates the standard maximum length of an LM rail. (See P.25)

- Static permissible moment*: Single block: static permissible moment with 1 LM block

Double blocks: static permissible moment with 2 blocks closely contacting with each other

- The LM block for SRG15A and 20A/20LA are top mount as a standard.

If the LM block is to be mountable from the top or the bottom, please specify, and the mounting holes (4 holes) of the LM block will be back spot-faced as with models SRG-C/LC.

The value in the parentheses represents the through hole dimension in the case the mounting hole is back spot-faced.

* Lubrication

Lithium soap group grease No. 2 (AFB-LF grease) is contained in model SRG as standard.

If you want any other grease or any types without grease, contact THK.

** Pilot holes for customers who request for grease nipples in addition to LaCS or Lubricator QZ.

They are not drilled through in order to prevent foreign material from entering the product.

If you want machining of grease nipple mounting, contact THK.

Models SRG-C, LC and SLC (35-100)

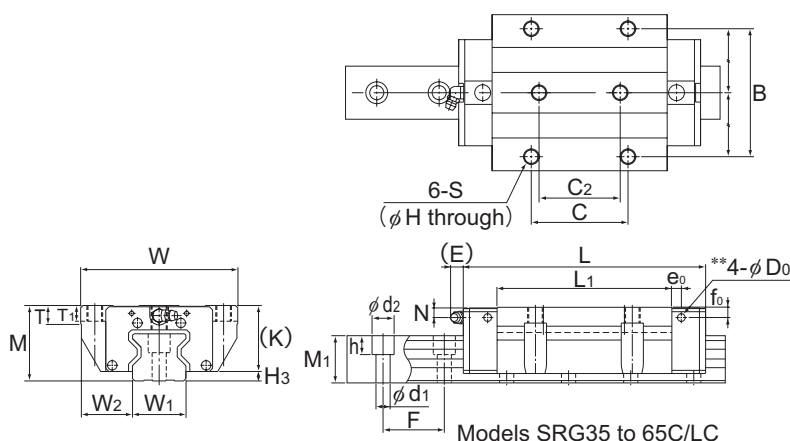
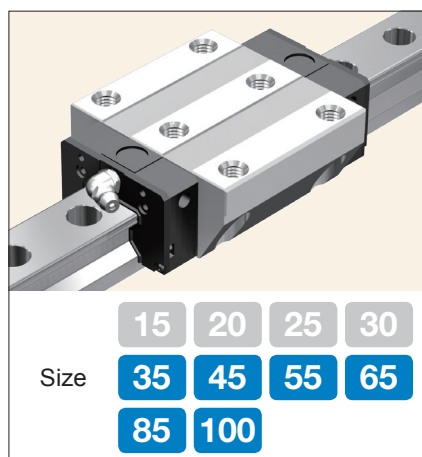

Model No.	Outer dimensions			LM block dimensions															Grease nipple
	Height	Width	Length	B	C	C ₂	S	H	L ₁	T	T ₁	K	N	E	e ₀	f ₀	D ₀		
	M	W	L																
SRG 35C SRG 35LC SRG 35SLC	48	100	125 155 180.8	82	62	52	M10	8.5	82.2 112.2 138.0	11.5	10	42	6.5	12	6	6	5.2	B-M6F	
SRG 45C SRG 45LC SRG 45SLC	60	120	155 190 231.5	100	80	60	M12	10.5	107 142 183.5	14.5	15	52	10	16	7	7	5.2	B-R1/8 (B-PT1/8)	
SRG 55C SRG 55LC SRG 55SLC	70	140	185 235 292	116	95	70	M14	12.5	129.2 179.2 236.2	17.5	18	60	12	16	9	8.5	5.2	B-R1/8 (B-PT1/8)	
SRG 65C SRG 65LC SRG 65SLC	90	170	244.9 303 380	142	110	82	M16	14.5	171.7 229.8 306.8	19.5	20	78.5	17	16	9	13.5	5.2	B-R1/8 (B-PT1/8)	
SRG 85LC	110	215	350	185	140	—	M20	17.8	250.8	30	35	94	22	16	15	22	8.2	B-R1/8 (B-PT1/8)	
SRG 100LC	120	250	395	220	200	—	M20	17.8	280.2	35	38	104	23	16	15	23	8.2	B-R1/4 (B-PT1/4)	

Model number coding

SRG45	LC	2	QZ	TT	HH	C0	+1200L	P	Z	T	- II
Model number	Type of LM block	No. of LM blocks used on the same rail	With QZ Lubricator	Contamination protection accessory symbol		Radial clearance symbol Normal (No symbol) Light preload (C1) Medium preload (C0)	LM rail length (in mm)	Accuracy symbol High accuracy grade (H) Precision grade (P)/Super precision grade (SP) Ultra precision grade (UP)	With plate cover	Symbol for LM rail jointed use	Symbol for No. of rails used on the same plane

Note) - The maximum length indicates the standard maximum length of an LM rail. (See P.25)

- Static permissible moment*: Single block: static permissible moment with 1 LM block

Double blocks: static permissible moment with 2 blocks closely contacting with each other

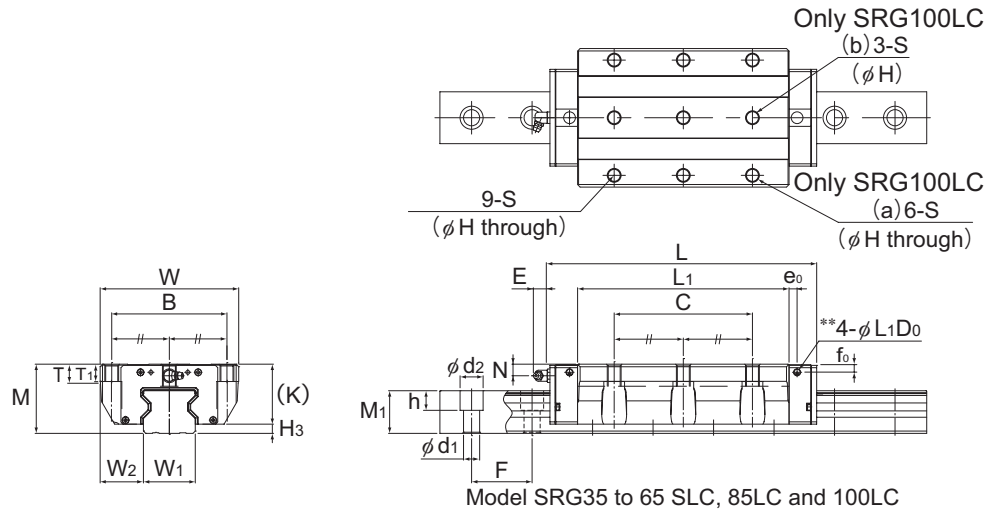

Unit: mm

H ₃	LM rail dimensions							Basic load rating		Static permissible moment kN-m*					Mass	
	Width W ₁ 0 -0.05	Height W ₂	Pitch M ₁	Pitch F	Length* d ₁ ×d ₂ ×h	Max	C kN	C ₀ kN	M _A		M _B		M _C	LM block kg	LM rail kg/m	
									1 block	Double blocks	1 block	Double blocks	1 block			
6	34	33	30	40	9×14×12	3000	59.1 76 87.9	119 165 199	1.66 3.13 4.53	10.1 17 23.9	1.66 3.13 4.53	10.1 17 23.9	2.39 3.31 4.09	1.9 2.4 3.2	6.9	
8	45	37.5	37	52.5	14×20×17	3090	91.9 115 139	192 256 328	3.49 6.13 9.99	20 32.2 50	3.49 6.13 9.99	20 32.2 50	4.98 6.64 8.91	3.7 4.5 6.3	11.6	
10	53	43.5	43	60	16×23×20	3060	131 167 210	266 366 488	5.82 10.8 19.1	33 57 93.7	5.82 10.8 19.1	33 57 93.7	8.19 11.2 15.6	5.9 7.8 10.7	15.8	
11.5	63	53.5	54	75	18×26×22	3000	219 278 352	441 599 811	12.5 22.7 41.3	72.8 120 202	12.5 22.7 41.3	72.8 120 202	16.8 22.1 30.9	12.5 16.4 22.3	23.7	
16	85	65	71	90	24×35×28	3000	497	990	45.3	239	45.3	239	51.9	26.2	35.7	
16	100	75	77	105	26×39×32	3000	601	1170	60	319	60	319	72.3	37.6	46.8	

- Note) - The maximum length indicates the standard maximum length of an LM rail. (See P.25)
 - Static permissible moment*: Single block: static permissible moment with 1 LM block
 Double blocks: static permissible moment with 2 blocks closely contacting with each other
 - The LM block mounting holes in part (a) (6 holes) of SRG100LC are through holes (full thread).
 The holes in part (b) (3 holes) have effective thread depth of 22 mm.

* Lubrication
 Lithium soap group grease No. 2 (AFB-LF grease) is contained in model SRG as standard.
 If you want any other grease or any types without grease, contact THK.

** Pilot holes for customers who request for grease nipples in addition to LaCS or Lubricator QZ.
 They are not drilled through in order to prevent foreign material from entering the product.
 If you want machining of grease nipple mounting, contact THK.

Models SRG-V/R and LV/LR (15-30)

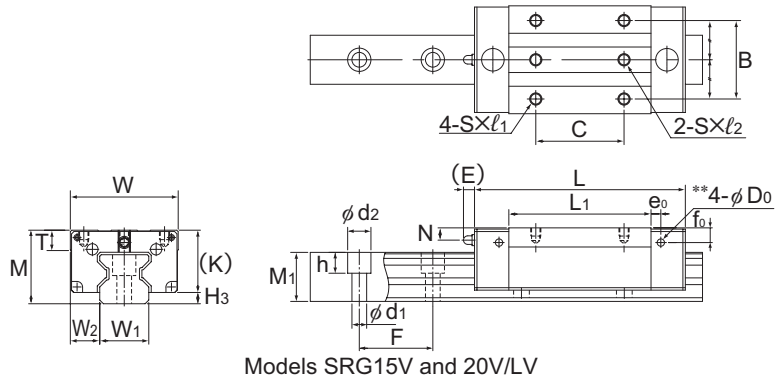
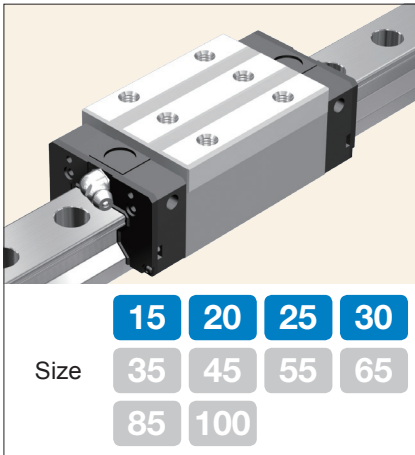

Model No.	Outer dimensions			LM block dimensions														Grease nipple
	Height	Width	Length	B	C	S	ℓ	ℓ ₁	ℓ ₂	L ₁	T	K	N	E	e ₀	f ₀	D ₀	
	M	W	L															
SRG 15V	24	34	69.2	26	26	M4	—	5	7.5	45	6	20	4	4.5	4	6	2.9	PB107
SRG 20V SRG 20LV	30	44	86.2 106.2	32	36 50	M5	—	7	9	58 78	8	25.4	5	4.5	4	6	2.9	PB107
SRG 25R SRG 25LR	40	48	95.5 115.1	35	35 50	M6	9	—	—	65.5 85.1	9.5	35.5	9.5	12	6	10.4	5.2	B-M6F
SRG 30R SRG 30LR	45	60	111 135	40	40 60	M8	10	—	—	75 99	12	40	9.5	12	6	10.5	5.2	B-M6F

Model number coding

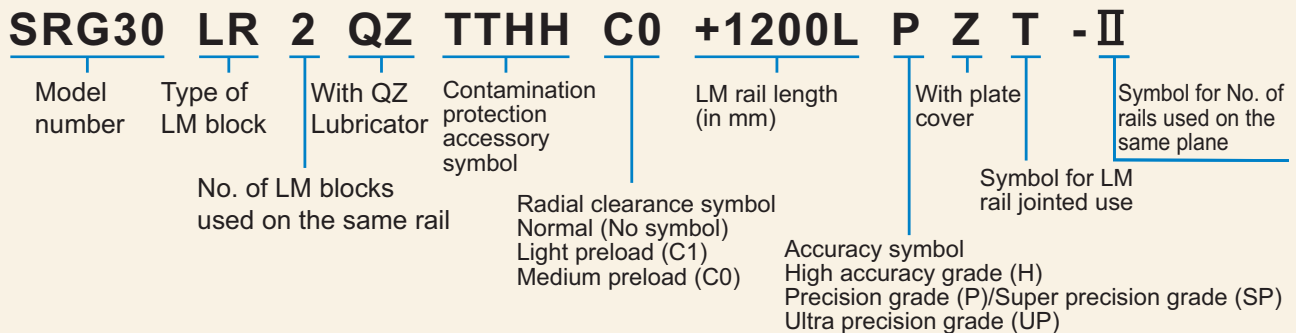

Note) This model number indicates that a single-rail unit constitutes one set. (i.e., required number of sets when 2 rails are used in parallel is 2 at a minimum.) Those models equipped with QZ Lubricator cannot have a grease nipple. When desiring a grease nipple for a model attached with QZ, contact THK.

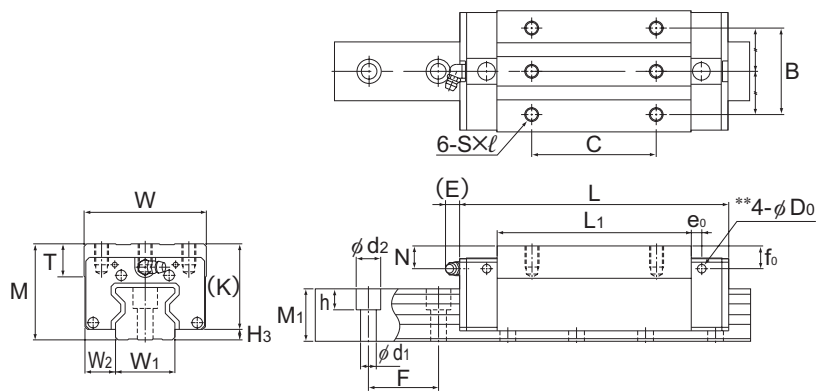

Models SRG25 to 30R/LR

Unit: mm

	LM rail dimensions							Basic load rating		Static permissible moment kN-m*					Mass	
	H ₃	Width		Height		Pitch	Length*	C	C ₀	M _A		M _B		M _C	LM block	LM rail
		W ₁	W ₂	M ₁	F	d ₁ ×d ₂ ×h				Max	1 block	Double blocks	1 block	Double blocks		
	4	15	9.5	15.5	30	4.5×7.5×5.3	3000	11.3	25.8	0.21	1.24	0.21	1.24	0.24	0.15	1.58
	4.6	20	12	20	30	6×9.5×8.5	3000	21 26.7	46.9 63.8	0.48 0.88	2.74 4.49	0.48 0.88	2.74 4.49	0.58 0.79	0.28 0.38	2.58
	4.5	23	12.5	23	30	7×11×9	3000	27.9 34.2	57.5 75	0.641 1.07	3.7 5.74	0.641 1.07	3.7 5.74	0.795 1.03	0.6 0.8	3.6
	5	28	16	26	40	9×14×12	3000	39.3 48.3	82.5 108	1.02 1.76	6.21 9.73	1.02 1.76	6.21 9.73	1.47 1.92	0.9 1.2	4.4

Note) - The maximum length indicates the standard maximum length of an LM rail. (See P.25)

- Static permissible moment*: Single block: static permissible moment with 1 LM block

Double blocks: static permissible moment with 2 blocks closely contacting with each other

* Lubrication

Lithium soap group grease No. 2 (AFB-LF grease) is contained in model SRG as standard.

If you want any other grease or any types without grease, contact THK.

** Pilot holes for customers who request for grease nipples in addition to LaCS or Lubricator QZ.

They are not drilled through in order to prevent foreign material from entering the product.

If you want machining of grease nipple mounting, contact THK.

Models SRG-V/R, LV/LR and SLV/SLR (35-65)

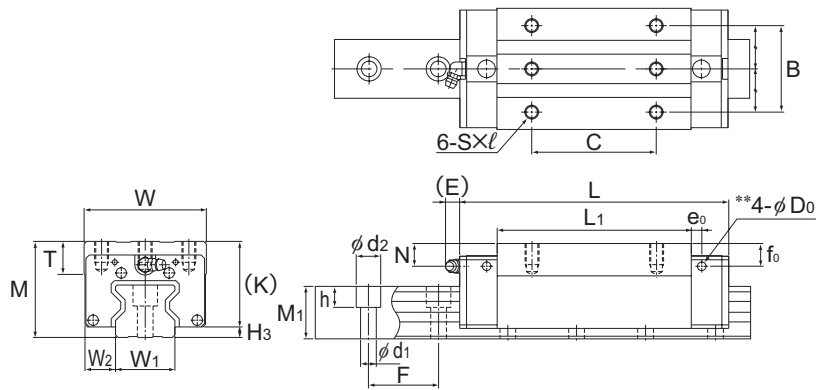
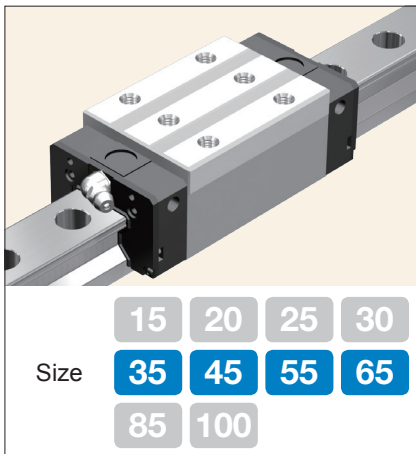

Models SRG35 to 65V/R/LV/LR

Model No.	Outer dimensions			LM block dimensions													Grease nipple
	Height	Width	Length	B	C	S	ℓ	L ₁	T	K	N	E	e ₀	f ₀	D ₀		
	M	W	L														
SRG 35R SRG 35LR SRG 35SLR	55	70	125 155 180.8	50	50 72 100	M8	12	82.2 112.2 138.0	18.5	49	13.5	12	6	13	5.2	B-M6F	
SRG 45R SRG 45LR SRG 45SLR	70	86	155 190 231.5	60	60 80 120	M10	20	107 142 183.5	24.5	62	20	16	7	17	5.2	B-R1/8 (B-PT1/8)	
SRG 55R SRG 55LR SRG 55SLR	80	100	185 235 292	75	75 95 150	M12	18	129.2 179.2 236.2	27.5	70	22	16	9	18.5	5.2	B-R1/8 (B-PT1/8)	
SRG 65V SRG 65LV SRG 65SLV	90	126	244.9 303 380	76	70 120 200	M16	20	171.7 229.8 306.8	19.5	78.5	17	16	9	13.5	5.2	B-R1/8 (B-PT1/8)	

Model number coding

SRG45	LR	2	QZ	TTHH	C0	+1200L	P	Z	T	-II
Model number	Type of LM block	No. of LM blocks used on the same rail	With QZ Lubricator	Contamination protection accessory symbol	Radial clearance symbol Normal (No symbol) Light preload (C1) Medium preload (C0)	LM rail length (in mm)	Accuracy symbol High accuracy grade (H) Precision grade (P)/Super precision grade (SP) Ultra precision grade (UP)	With plate cover	Symbol for LM rail jointed use	Symbol for No. of rails used on the same plane

Note) This model number indicates that a single-rail unit constitutes one set. (i.e., required number of sets when 2 rails are used in parallel is 2 at a minimum.)
Those models equipped with QZ Lubricator cannot have a grease nipple. When desiring a grease nipple for a model attached with QZ, contact THK.

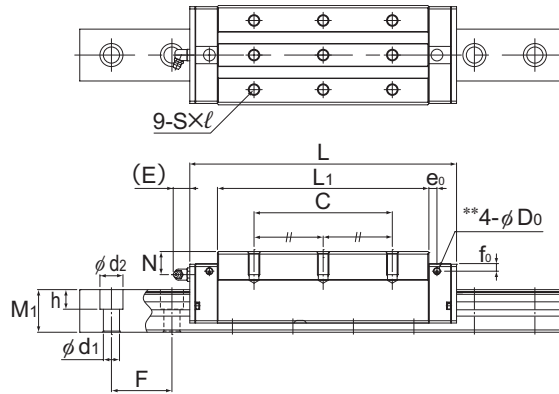
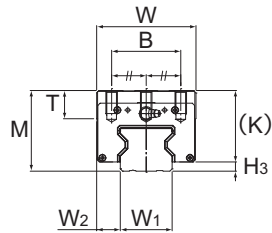

Models SRG35 to 65 SLR/SLV

Unit: mm

	LM rail dimensions							Basic load rating		Static permissible moment kN-m*					Mass	
	Width $\begin{matrix} W_1 \\ 0 \\ -0.05 \end{matrix}$	Height W_2	Pitch M_1	Pitch F	Length* $d_1 \times d_2 \times h$	Max	C kN	C ₀ kN	M_A		M_B		M_C	LM block kg	LM rail kg/m	
									1 block	Double blocks	1 block	Double blocks				
6	34	18	30	40	9×14×12	3000	59.1 76 87.9	119 165 199	1.66 3.13 4.53	10.1 17 23.9	1.66 3.13 4.53	10.1 17 23.9	2.39 3.31 4.09	1.6 2.1 2.6	6.9	
8	45	20.5	37	52.5	14×20×17	3090	91.9 115 139	192 256 328	3.49 6.13 9.99	20 32.2 50	3.49 6.13 9.99	20 32.2 50	4.98 6.64 8.91	3.2 4.1 5.4	11.6	
10	53	23.5	43	60	16×23×20	3060	131 167 210	266 366 488	5.82 10.8 19.1	33 57 93.7	5.82 10.8 19.1	33 57 93.7	8.19 11.2 15.6	5 6.9 9.2	15.8	
11.5	63	31.5	54	75	18×26×22	3000	219 278 352	441 599 811	12.5 22.7 41.3	72.8 120 202	12.5 22.7 41.3	72.8 120 202	16.8 22.1 30.9	9.0 12.1 16.1	23.7	

Note) - The maximum length indicates the standard maximum length of an LM rail. (See P.25)

- Static permissible moment*: Single block: static permissible moment with 1 LM block

Double blocks: static permissible moment with 2 blocks closely contacting with each other

* Lubrication

Lithium soap group grease No. 2 (AFB-LF grease) is contained in model SRG as standard.

If you want any other grease or any types without grease, contact THK.

** Pilot holes for customers who request for grease nipples in addition to LaCS or Lubricator QZ.

They are not drilled through in order to prevent foreign material from entering the product.

If you want machining of grease nipple mounting, contact THK.

Models SRN-C and LC (35-65)

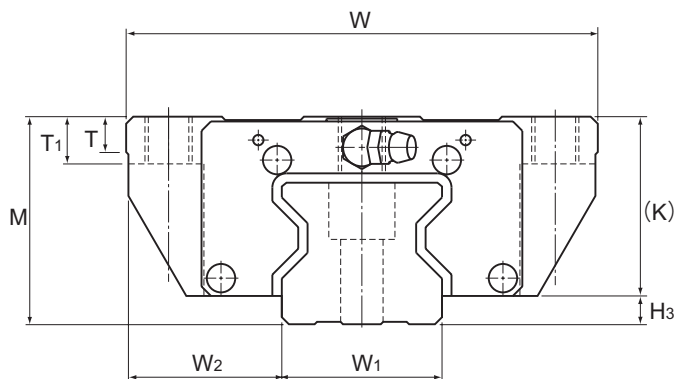
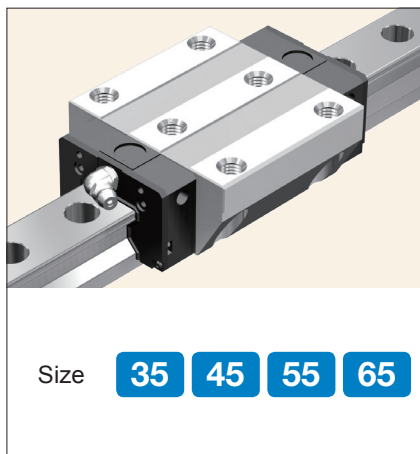

Model No.	Outer dimensions			LM block dimensions																Grease nipple	H ₃
	Height	Width	Length	B	C	C ₂	S	H	L ₁	T	T ₁	K	N	E	e ₀	f ₀	D ₀				
	M	W	L																		
SRN 35C SRN 35LC	44	100	125 155	82	62	52	M10	8.5	82.2 112.2	7.5	10	38	6.5	12	8	7	5.2	B-M6F	6		
SRN 45C SRN 45LC	52	120	155 190	100	80	60	M12	10.5	107 142	7.5	15	45	7	12	8.5	7.6	5.2	B-M6F	7		
SRN 55C SRN 55LC	63	140	185 235	116	95	70	M14	12.5	129 179.2	10.5	18	53	8	16	10	9.8	5.2	B-R1/8 (B-PT1/8)	10		
SRN 65LC	75	170	303	142	110	82	M16	14.5	229.8	19.5	20	65	14	16	9	13	5.2	B-R1/8 (B-PT1/8)	11.5		

Model number coding

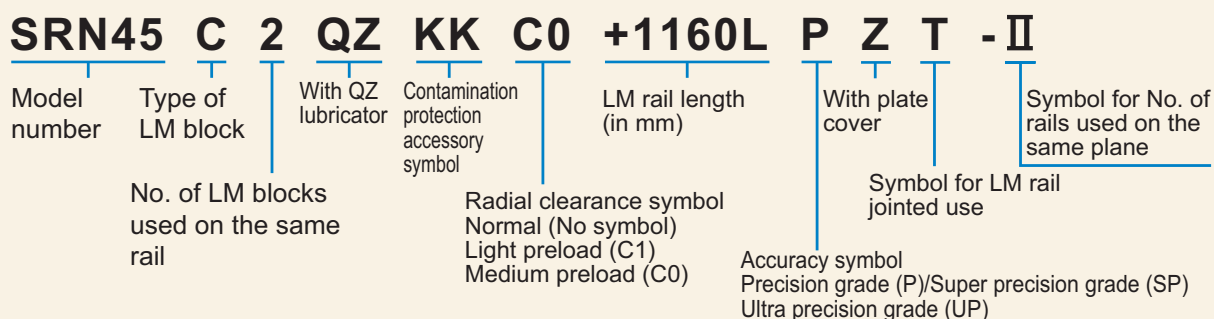

Note) This model number indicates that a single-rail unit constitutes one set. (i.e., required number of sets when 2 rails are used in parallel is 2 at a minimum.) Those models equipped with QZ Lubricator cannot have a grease nipple. When desiring a grease nipple for a model attached with QZ, contact THK.

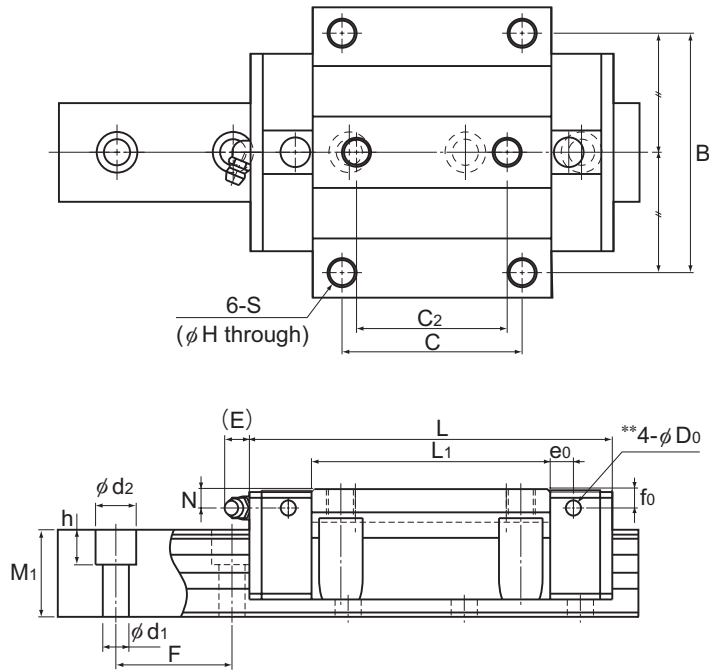

Unit: mm

	LM rail dimensions						Basic load rating		Static permissible moment kN-m*					Mass	
	Width		Height	Pitch		Length*	C	C ₀	M _A		M _B		M _C	LM block	LM rail
	W ₁ 0 -0.05	W ₂	M ₁	F	d ₁ ×d ₂ ×h	Max	kN	kN	1 block	Double blocks	1 block	Double blocks	1 block	kg	kg/m
	34	33	30	40	9×14×12	3000	59.1 76	119 165	1.66 3.13	10.1 17	1.66 3.13	10.1 17	2.39 3.31	1.6 2	6.9
	45	37.5	36	52.5	14×20×17	3090	91.9 115	192 256	3.49 6.13	20 32.2	3.49 6.13	20 32.2	4.98 6.64	3 3.6	11.3
	53	43.5	43	60	16×23×20	3060	131 167	266 366	5.82 10.8	33 57	5.82 10.8	33 57	8.19 11.2	4.9 6.4	15.8
	63	53.5	49	75	18×26×22	3000	278	599	22.7	120	22.7	120	22.1	12.7	21.3

Note) - The maximum length indicates the standard maximum length of an LM rail. (See P.25)

- Static permissible moment*: Single block: static permissible moment with 1 LM block

Double blocks: static permissible moment with 2 blocks closely contacting with each other

* Lubrication

Lithium soap group grease No. 2 (AFB-LF grease) is contained in model SRN as standard.

If you want any other grease or any types without grease, contact THK.

** Pilot holes for customers who request for grease nipples in addition to LaCS or Lubricator QZ.

They are not drilled through in order to prevent foreign material from entering the product.

If you want machining of grease nipple mounting, contact THK.

Models SRN-R and LR (35-65)

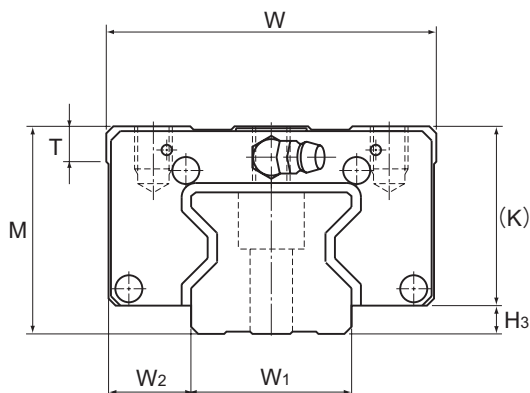
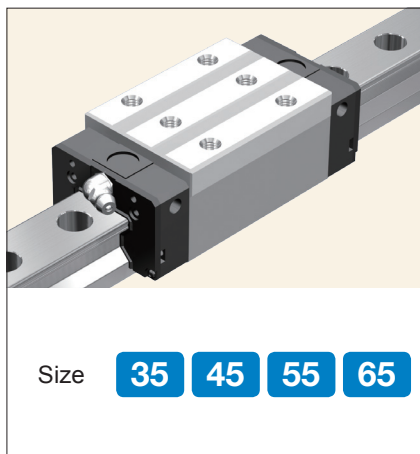

Model No.	Outer dimensions			LM block dimensions												Grease nipple	H ₃
	Height	Width	Length	B	C	S×ℓ	L ₁	T	K	N	E	e ₀	f ₀	D ₀			
	M	W	L														
SRN 35R SRN 35LR	44	70	125 155	50	50 72	M8×9	82.2 112.2	7.5	38	6.5	12	8	7	5.2	B-M6F	6	
SRN 45R SRN 45LR	52	86	155 190	60	60 80	M10×11	107 142	7.5	45	7	12	8.5	7.6	5.2	B-M6F	7	
SRN 55R SRN 55LR	63	100	185 235	75	75 95	M12×13	129 179.2	10.5	53	8	16	10	9.8	5.2	B-R1/8 (B-PT1/8)	10	
SRN 65LR	75	126	303	76	120	M16×16	229.8	19.5	65	14	16	9	13	5.2	B-R1/8 (B-PT1/8)	11.5	

Model number coding

SRN45	LR	2	QZ	KK	C0	+1200L	P	Z	T	-II
Model number	Type of LM block	No. of LM blocks used on the same rail	With QZ lubricator	Contamination protection accessory symbol	Radial clearance symbol Normal (No symbol) Light preload (C1) Medium preload (C0)	LM rail length (in mm)	Accuracy symbol Precision grade (P)/Super precision grade (SP) Ultra precision grade (UP)	With plate cover	Symbol for LM rail jointed use	Symbol for No. of rails used on the same plane

Note) This model number indicates that a single-rail unit constitutes one set. (i.e., required number of sets when 2 rails are used in parallel is 2 at a minimum.) Those models equipped with QZ Lubricator cannot have a grease nipple. When desiring a grease nipple for a model attached with QZ, contact THK.

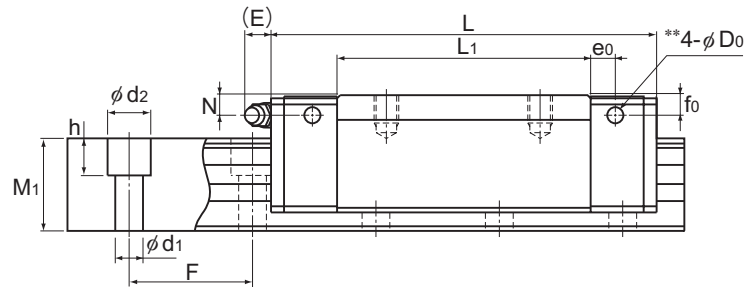
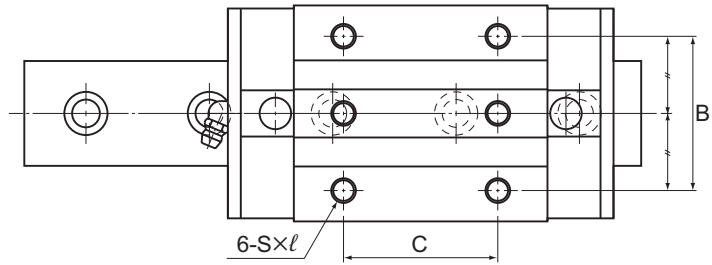

Unit: mm

	LM rail dimensions						Basic load rating		Static permissible moment kN-m*					Mass	
	Width		Height	Pitch		Length*	C	C ₀	M _A		M _B		M _C	LM block	LM rail
	W ₁ 0 -0.05	W ₂	M ₁	F	d ₁ ×d ₂ ×h	Max	kN	kN	1 block	Double blocks	1 block	Double blocks	1 block	kg	kg/m
	34	18	30	40	9×14×12	3000	59.1 76	119 165	1.66 3.13	10.1 17	1.66 3.13	10.1 17	2.39 3.31	1.1 1.4	6.9
	45	20.5	36	52.5	14×20×17	3090	91.9 115	192 256	3.49 6.13	20 32.2	3.49 6.13	20 32.2	4.98 6.64	1.9 2.5	11.3
	53	23.5	43	60	16×23×20	3060	131 167	266 366	5.82 10.8	33 57	5.82 10.8	33 57	8.19 11.2	3.2 4.5	15.8
	63	31.5	49	75	18×26×22	3000	278	599	22.7	120	22.7	120	22.1	9.4	21.3

Note) - The maximum length indicates the standard maximum length of an LM rail. (See P.25)

- Static permissible moment*: Single block: static permissible moment with 1 LM block

Double blocks: static permissible moment with 2 blocks closely contacting with each other

* Lubrication

Lithium soap group grease No. 2 (AFB-LF grease) is contained in model SRN as standard.
If you want any other grease or any types without grease, contact THK.

** Pilot holes for customers who request for grease nipples in addition to LaCS or Lubricator QZ.

They are not drilled through in order to prevent foreign material from entering the product.
If you want machining of grease nipple mounting, contact THK.

SRG/SRN

Standard Length and Maximum Length of the LM Rail

The table below shows the standard length and the maximum length of the LM rail for models SRG/SRN. If the maximum length of the desired LM rail exceeds the corresponding value, connected rails will be used. Contact THK for details.

For the G dimension when a special length is required, we recommend selecting the corresponding G value from the table. The longer the G dimension, the less stable the G area may become after installation, thus adversely affecting the accuracy.

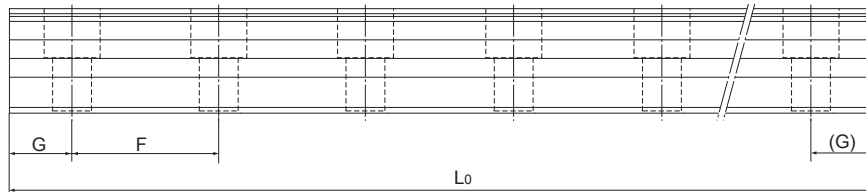

Standard Length and Maximum Length of the LM Rail for Models SRG/SRN

Unit: mm

Model No.	SRG15	SRG20	SRG 25	SRG 30	SRG/SRN 35	SRG/SRN 45	SRG/SRN 55	SRG/SRN 65	SRG 85	SRG 100
Standard LM rail length (L ₀)	160	220	220	280	280	570	780	1270	1530	1340
	220	280	280	360	360	675	900	1570	1890	1760
	280	340	340	440	440	780	1020	2020	2250	2180
	340	400	400	520	520	885	1140	2620	2610	2600
	400	460	460	600	600	990	1260			
	460	520	520	680	680	1095	1380			
	520	580	580	760	760	1200	1500			
	580	640	640	840	840	1305	1620			
	640	700	700	920	920	1410	1740			
	700	760	760	1000	1000	1515	1860			
	760	820	820	1080	1080	1620	1980			
	820	940	940	1160	1160	1725	2100			
	940	1000	1000	1240	1240	1830	2220			
	1000	1060	1060	1320	1320	1935	2340			
	1060	1120	1120	1400	1400	2040	2460			
	1120	1180	1180	1480	1480	2145	2580			
	1180	1240	1240	1560	1560	2250	2700			
	1240	1360	1300	1640	1640	2355	2820			
	1360	1480	1360	1720	1720	2460	2940			
	1480	1600	1420	1800	1800	2565	3060			
1600	1720	1480	1880	1880	2670					
		1840	1960	1960	2775					
		1960	2040	2040	2880					
		2080	2200	2200	2985					
		2200	2360	2360	3090					
			1960	2520	2520					
			2080	2680	2680					
			2200	2840	2840					
			2320	3000	3000					
			2440							
Standard pitch F	30	30	30	40	40	52.5	60	75	90	105
G	20	20	20	20	20	22.5	30	35	45	40
Max Length	2500	3000	3000	3000	3000	3090	3060	3000	3000	3000

Note 1: The maximum length varies with accuracy grades. Contact THK for details.

Note 2: If connected rails are not allowed and a greater length than the maximum values above is required, contact THK.

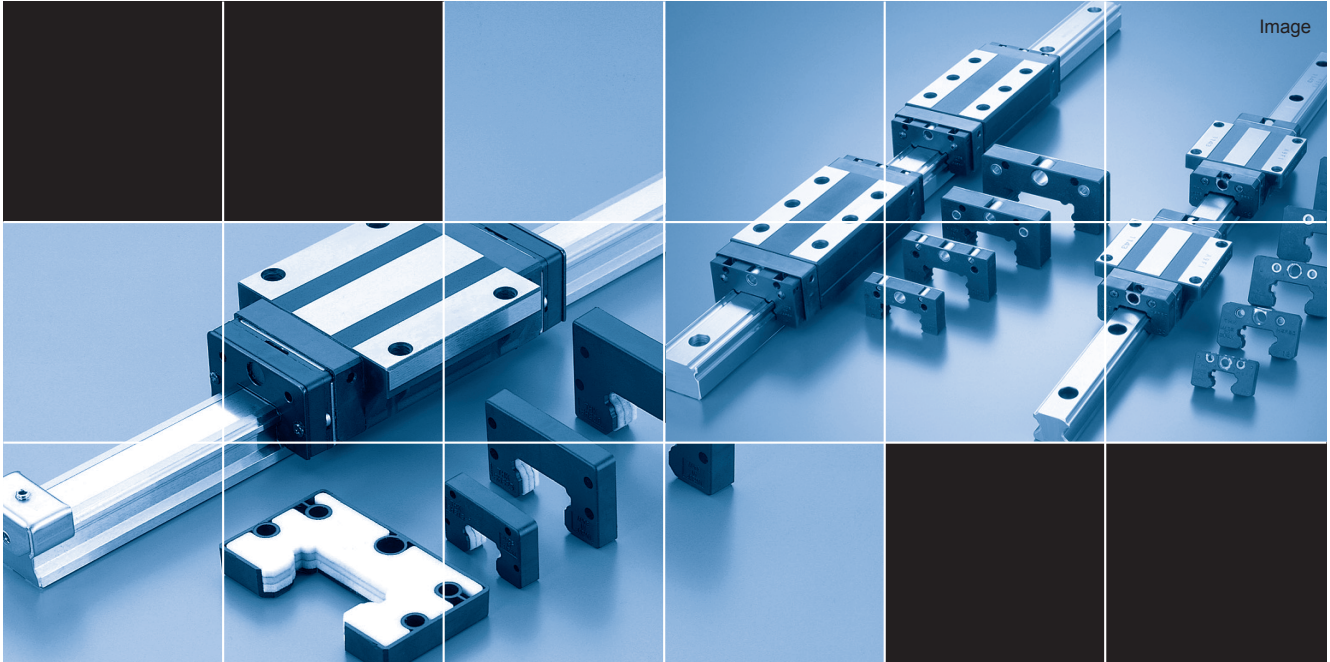

Image

SRG/SRN OPTIONS

Options

For models SRG/SRN, contamination protection and lubrication accessories are available. You can make a selection according to the application or mounting location.

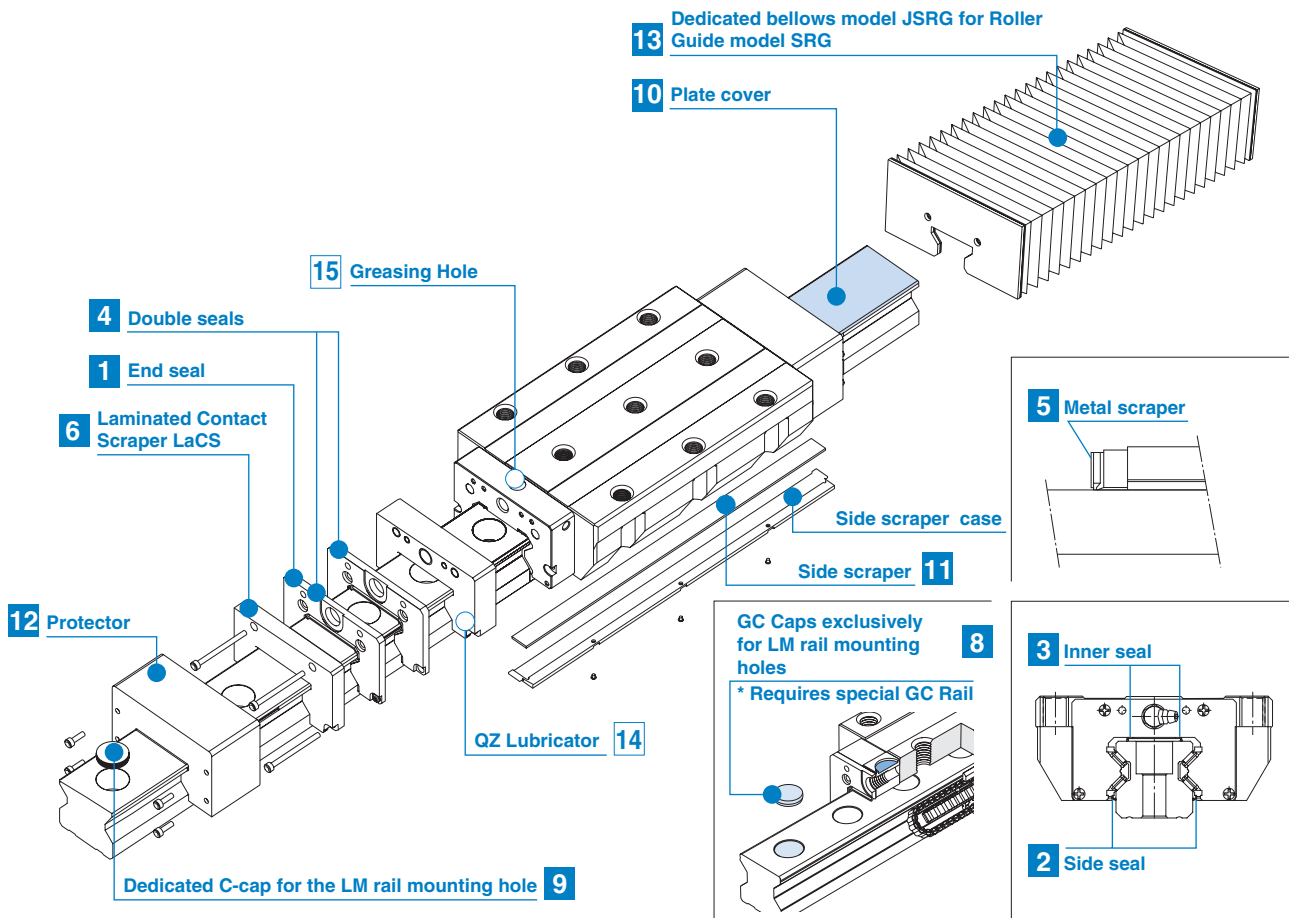

Contamination Protection Accessories

When foreign material enters an LM system, it will cause abnormal wear or shorten the service life, and it is necessary to prevent foreign material from entering the system. Therefore, when possible entry of foreign material is predicted, it is important to select an effective sealing device or contamination protection device that meets the atmospheric conditions.

1 End seal
Used in locations exposed to dust

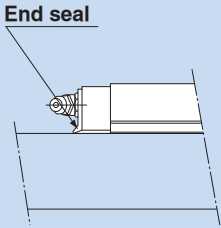

The diagram shows a cross-section of an LM block with an end seal installed at one end. A label 'End seal' points to the seal.

2 Side Seal
Used in locations where dust may enter the LM block from the side or bottom surface, such as vertical, horizontal and inverted mounts

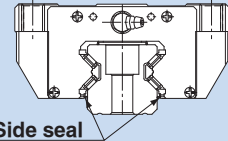

The diagram shows a cross-section of an LM block with a side seal installed on the side. A label 'Side seal' points to the seal.

3 Inner seal
Used in locations severely exposed to dust or cutting chips

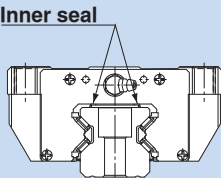

The diagram shows a cross-section of an LM block with an inner seal installed inside the block. A label 'Inner seal' points to the seal.

4 Double Seals
Used in locations exposed to much dust or many cutting chips

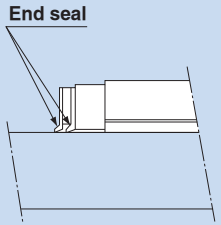

The diagram shows a cross-section of an LM block with two seals installed at one end. A label 'End seal' points to the outer seal.

Table 1 Symbols of Contamination Protection Accessories for Models SRG/SRN

Symbol	Contamination protection accessories
UU	End seal
SS	End seal + side seal + inner seal
DD	End seal + side seal + inner seal
GG	LiCS
PP	LiCS + side seal + inner seal
ZZ	End seal + side seal + inner seal+ metal scraper
KK	Double seals + side seal + inner seal + metal scraper
SSHH	End seal + side seal + inner seal + LaCS
DDHH	Double seals + side seal + inner seal + LaCS
ZZHH	End seal + side seal + inner seal + metal scraper + LaCS
KKHH	Double seals + side seal + inner seal + metal scraper + LaCS
JJHH	With end seal + side seal + inner seal + LaCS + protector (serving also as metal scraper)
TTHH	With double seals + side seal + inner seal + LaCS + protector (serving also as metal scraper)

Note: Light Sliding Resistance Contact Seal LiCS (GG and PP) is available only for model SRG15.

Seals and Scrapers

1 to 4 Seals

THK offers seals such as an end seal made of special synthetic rubber with high wear resistance and a side seal designed to increase the contamination protection effect.

When a contamination protection accessory is required, specify the desired item with the corresponding symbol provided in Table 3.

For supported models for contamination protection accessories and a specific overall LM block length with a contamination protection accessory attached (dimension L), see Tables 4.

Seal resistance value

For the maximum seal resistance value per LM block when a lubricant is applied on seals for models SRG/SRN...SS, refer to the corresponding value provided in Table 2.

Table 2 Maximum Seal Resistance Value of Seals for models SRG/SRN...SS

Model No.	Seal resistance
SRG 15	13
SRG 20	18
SRG 25	19
SRG 30	24
SRG 35	30
SRG 45	30
SRG 55	35
SRG 65	40
SRG 85	47
SRG 100	53

The seal resistance values for models SRN 35 to 65 are equal to that of model SRG.

5 to 6 Scrapers

Laminated Contact Scraper LaCS®

For locations with an adverse atmosphere, Laminated Contact Scraper LaCS is available.

LaCS removes minute foreign material adhering to the LM rail in multiple stages and prevents it from entering the LM block with its laminated contact structure (3-layer scraper).

Features

- Since the 3 layers of scrapers fully contact the LM rail, LaCS is highly capable of removing minute foreign material.
- Since it uses oil-impregnated foam synthetic rubber with a self-lubricating function, low friction resistance is achieved.

Basic Specifications of LaCS

- Service temperature range of LaCS: -20°C to +80°C
- Maximum resistance for LaCS: see the table on the right.

Note: LaCS is not sold alone.

Table 3 Maximum resistance for LaCS

Model No.	Maximum resistance for LaCS
SRG 20	6.1
SRG 25	6.9
SRG 30	8.2
SRG 35	9.1
SRG 45	14.3
SRG 55	18.2
SRG 65	26.0
SRN 65	22.1

The resistances of LaCS for models SRN 35 to 55 are equal to that of model SRG.

Note 1: The indicated resistance values consist only of the resistance of LaCS and do not include sliding resistance of the LM block, seals and the likes.

Note 2: For the maximum service velocity of LaCS, contact THK.

Metal Scraper

Used in locations where welding spatter may adhere to the LM rail

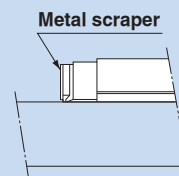

LaCS

Used in harsh environments exposed to foreign material such as fine dust and liquids

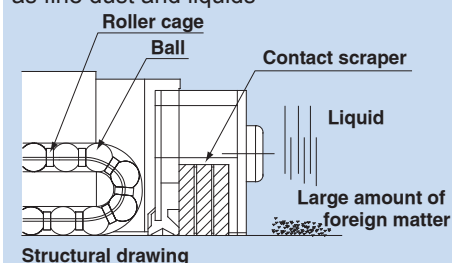

7 Light Sliding Resistance Contact Seal LiCS

LiCS is a contact seal with a low sliding resistance. It is effective in removing dust and the like from the raceway and retaining a lubricant such as grease. With its very low sliding resistance, LiCS achieves a smooth and stable motion.

LiCS

Available only for model SRG 15

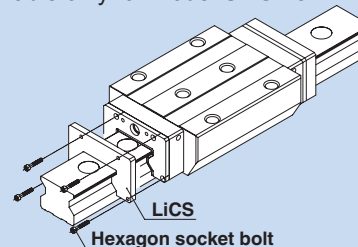

■ For Models Attached with Contamination Protection Accessories SSHH, DDHH, ZZHH or KKHH

Models attached with contamination protection accessories SSHH, DDHH, ZZHH or KKHH have a grease nipple in the location indicated in the figure below. The table on the right shows incremental dimensions with the grease nipple.

Unit: mm

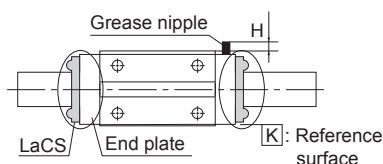

Note: When desiring the mounting location for the grease nipple other than the one indicated above, contact THK.

Model No.	Incremental dimension with grease nipple H	Nipple type
SRG 25C/LC	—	A-M6F
SRG 25R/LR	7.2	A-M6F
SRG 30C/LC	—	A-M6F
SRG 30R/LR	7.2	A-M6F
SRG 35C/LC	—	A-M6F
SRG 35R/LR	7.2	A-M6F
SRG 45C/LC	—	A-M6F
SRG 45R/LR	7.2	A-M6F
SRG 55C/LC	—	A-M6F
SRG 55R/LR	7.2	A-M6F
SRG 65C/LC	—	A-M6F
SRG 65R/LR	6.2	A-M6F

■ For Models Attached with Contamination Protection Accessories UU or SS

For the mounting location of the grease nipple (N) and its incremental dimension (E) when contamination protection accessories UU or SS are attached, see the corresponding dimensional table (see page 13 to 24).

■ For Models Attached with Contamination Protection Accessories DD, ZZ or KK

For the mounting location of the grease nipple and its incremental dimension when contamination protection accessories DD, ZZ or KK are attached, contact THK.

Table 4 Overall LM Block Length (Dimension L) of Model SRG/SRN with a Contamination Protection Accessory Attached

Unit: mm

Model No.	L											
	UU	SS	DD	ZZ	KK	SSHH	DDHH	ZZHH	KKHH	JJHH	TTHH	
SRG	15A/V	69.2	69.2	71.2	—	—	—	—	—	—	—	
	20A/V	86.2	86.2	88.2	89.6	91.6	105.2	107.2	107.6	109.6	—	
	20LA/LV	106.2	106.2	108.2	109.6	111.6	125.2	127.2	127.6	129.6	—	
	25C/R	95.5	95.5	100.5	100.5	105.5	115.3	120.3	117.7	122.7	—	
	25LC/LR	115.1	115.1	120.1	120.1	125.1	134.9	139.9	137.3	142.3	—	
	30C/R	111	111	118	116	123	130.8	137.8	133.2	140.2	—	
	30LC/LR	135	135	142	140	147	154.8	161.8	157.2	164.2	—	
	35C/R	125	125	132.8	130.7	138.5	142.6	150.4	151	158.8	150.8	158.6
	35LC/LR	155	155	162.8	160.7	168.5	172.6	180.4	181	188.8	180.8	188.6
	35SLC/SLR	180.8	180.8	188.6	186.5	194.3	198.4	206.2	206.8	214.6	206.6	214.4
	45C/R	155	155	164.2	161.5	170.7	175.6	184.8	184.8	194	184.6	193.8
	45LC/LR	190	190	199.2	196.5	205.7	210.6	219.8	219.8	229	219.6	228.8
	45SLC/SLR	231.5	231.5	240.7	238	247.2	252.1	261.3	261.3	270.5	261.1	270.3
	55C/R	185	185	194.2	191.5	200.7	205.6	214.8	214.8	224	214.6	223.8
	55LC/LR	235	235	244.2	241.5	250.7	255.6	264.8	264.8	274	264.6	273.8
	55SLC/SLR	292	292	301.2	298.5	307.7	312.6	321.8	321.8	331	321.6	330.8
	65C/V	244.9	244.9	256.1	252.5	263.7	268.9	280.1	280.1	291.3	279.9	291.1
	65LC/LV	303	303	314.2	310.6	321.8	327	338.2	338.2	349.4	338	349.2
	65SLC/SLV	380	380	391.2	387.6	398.8	404	415.2	415.2	426.4	415	426.2
	85LC	350	350	361.2	361	372.2	—	—	—	—	—	—
100LC	395	395	406.2	411	422.2	—	—	—	—	—	—	
SRN	35C/R	125	125	132.8	131.4	139.2	148.6	156.4	151	158.8	—	
	35LC/LR	155	155	162.8	161.4	169.2	178.6	186.4	181	188.8	—	
	45C/R	155	155	164.2	162.2	171.4	182	191.2	185.2	194.4	—	
	45LC/LR	190	190	199.2	197.2	206.4	217	226.2	220.2	229.4	—	
	55C/R	185	185	194.2	192.2	201.4	212	221.2	215.2	224.4	—	
	55LC/LR	235	235	244.2	242.2	251.4	262	271.2	265.2	274.4	—	
	65LC/LR	303	303	314.2	311.4	322.6	335.4	346.6	338.6	349.8	—	

* The overall LM block length (L) of YY type (with side scraper) is also the same.

8 GC Cap

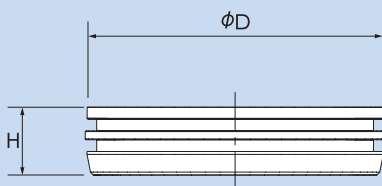

8 Metal Cap Dedicated for LM Rail Mounting Holes GC Cap

GC cap is a metallic cap that plugs the LM rail mounting hole (article compliant with the RoHS Directives). It prevents the entrance of foreign material and coolant from the LM rail top face (mounting hole) under harsh environments, and significantly increases the dust control performance of the LM Guide if used with a dust control seal.

Model No.	GC Cap Model No.	Bolt used	Main dimensions(mm)	
			D	H
20	GC5	M5	9.86	2.5
25	GC6	M6	11.36	2.5
30	GC8	M8	14.36	3.5
35	GC8	M8	14.36	3.5
45	GC12	M12	20.36	4.6
55	GC14	M14	23.36	5.0
65	GC16	M16	26.36	5.0
85	GC22	M22	35.36	5.0
100	GC24	M24	39.36	5.0

If designating an LM Guide model attached with GC cap, observe the following example of model number coding.

Example of model number coding

SRG45 LR 2 QZ KKHH C0 +1200L P T - II GC				
Model number	No. of LM blocks used on the same rail	Symbol for contamination protection accessory (see page 22)	LM rail length (in mm)	No. of LM rails used on the same plane
Type of LM block	With QZ Lubricator attached	Radial clearance symbol (see page 9)	Accuracy symbol (page 10)	With GC cap

- Note 1: The LM rail of an LM Guide model attached with GC cap is of special type.
- Note 2: GC cap cannot be mounted on an LM rail made of stainless steel or provided with surface treatment.
- Note 3: If using the product in a special environment such as vacuum, low temperature or high temperature, contact THK.
- Note 4: GC cap is not sold alone. It is always provided in combination with LM Guide.
- Note 5: The mouth of the LM rail mounting hole is not chamfered. Take care not to hurt your hand when attaching GC cap.
- Note 6: After attaching GC cap, be sure to level and clean (wipe off) the top face of the LM rail.

9 Dedicated Cap "C" for LM Rail Mounting Holes

If any of the LM rail mounting holes of an LM Guide is filled with cutting chips of foreign material, they may enter the LM block structure. Entry of such foreign material can be prevented by covering each LM rail mounting hole with the dedicated cap so that the top of the mounting holes are on the same level as the LM rail top face.

Since the dedicated cap "C" for LM rail mounting holes uses a special synthetic resin with high oil resistance and high wear resistance, it is highly durable.

When placing an order, specify the desired cap type with the corresponding cap number indicated in the table on the right.

Main Dimensions of the Dedicated Cap

Model No.	Cap "C" Model No.	Bolt used	Main dimensions(mm)	
			D	H
15	C4	M4	7.8	1.0
20	C5	M5	9.8	2.4
25	C6	M6	11.4	2.7
30	C8	M8	14.4	3.7
35	C8	M8	14.4	3.7
45	C12	M12	20.5	4.7
55	C14	M14	23.5	5.7
65	C16	M16	26.5	5.7
85	C22	M22	35.5	5.7
100	C24	M24	39.5	5.7

Note: The main dimensions of the dedicated cap for models SRN 35 to 65 are the same as that of model SRG.

10 Plate Cover

By covering the LM rail's mounting holes with ultra-thin stainless steel (SUS304) plates, the sealability of the end seals increase drastically, helping prevent foreign materials and liquid from entering from the top of the LM rail. Contact THK for further details regarding mounting.

Note 1: The Models SRG/SRN with plate cover are not a standard specifications. (Please note it is not possible to add just the plate cover afterwards.)

Note 2: The LM block must be removed from the LM rail when mounting. When doing this, a removing/mounting jig is required. Please contact THK for details.

Note 3: When LM rails are joined to exceed the maximum manufactured length, their plate covers must also be joined. The joined plate covers must be level at the points where they make contact. Contact THK for details.

Note 4: Plate covers are available for models SRG 35 to 65.

Dedicated Cap "C" for LM Rail Mounting Holes

9

Prevents cutting chips from entering the LM rail mounting holes

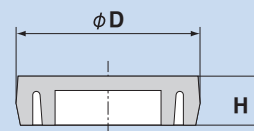
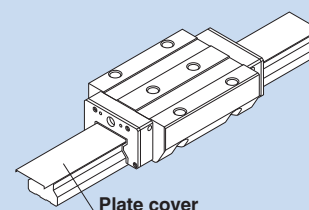

Plate cover

10



11 Side Scraper

Spattering of coolant and presence of minute foreign materials create an extremely harsh environment for the LM Guide, and may result in premature failure. The side scraper is fitted to the bottom of the LM block and minimizes foreign material entering from the side of the LM Guide, and is particularly effective when the LM Guide is placed inverted or wall-mounted.

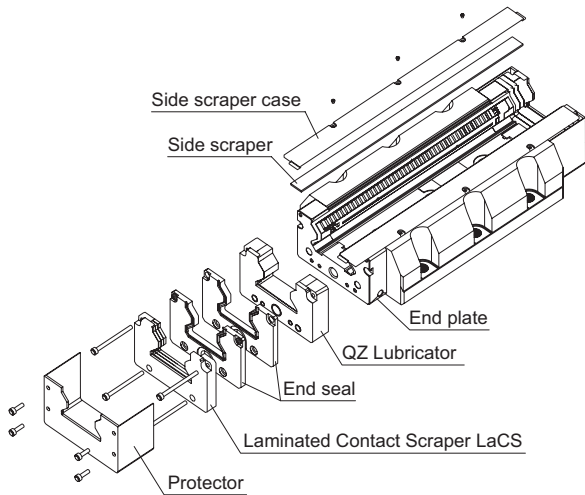
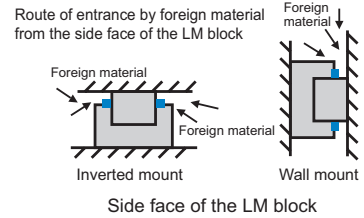

12 Protector

The protector prevents the influx of coolant or minute foreign material from entering the block, in addition to protecting the contamination protection accessories fitted to the LM block, and also serves as the metal scraper. The protector can be fitted to both ends of the block if it is a block fitted with the HH accessory (with LaCS). Take note that the overall length of the LM block will increase slightly.

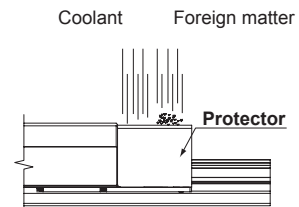

Configuration diagram of the inside the protector
(Ex: in case of QZJJHH Type)

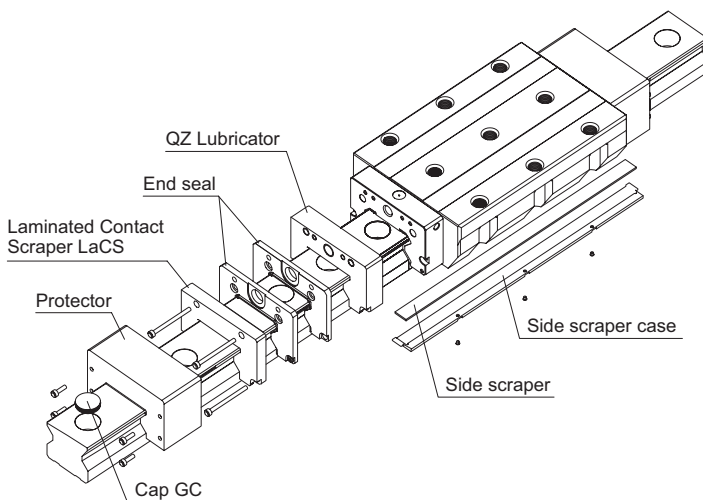
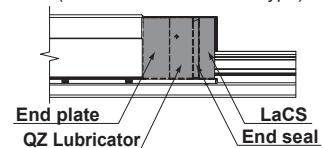

Removing/mounting Jig

When assembling the guide, do not remove the LM block from the LM rail whenever possible. If it is inevitable to remove the LM block due to the assembly procedure, be sure to use the removing/mounting jig.

Mounting the LM block without using the removing/mounting jig may lead some of the rolling elements to fall off from the LM block due to entry of foreign material, damage to internal parts or slight inclination. In addition, using the LM block with some of the rolling elements missing will cause the LM system to be damaged early. Be sure to use the removing/mounting jig. When using the removing/mounting jig, do not incline the jig, and match the end of the jig with that of the LM block. If any of the rolling elements falls off from the LM block, do not use the product, and be sure to contact THK. The removing/mounting jig is not provided as standard. When desiring to use it, contact THK.

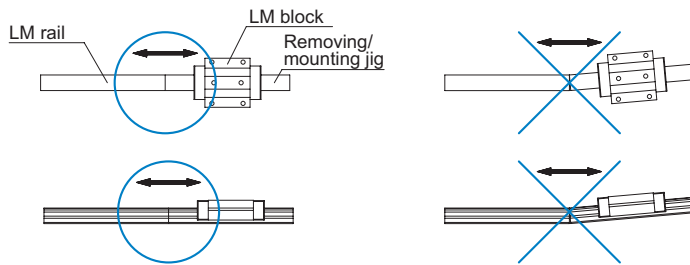

Removing/mounting jig

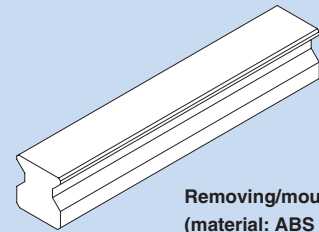

Removing/mounting jig
(material: ABS resin)

13 Dedicated Bellows JSRG for Model SRG

For locations with even worse working conditions, dedicated bellows are available. The table below shows the dimensions of the dedicated bellows. Specify the corresponding bellows model number shown below.

Dimensions of JSRG

Unit: mm

Model No.	Main dimensions												
	W	H	H ₁	P	p	b ₁	t ₁		b ₂	t ₂	t ₃	t ₄	
							A/C	R/V					
JSRG	15	55	27	27	14.2	12.7	28	10.3	10.3	—	—	10.6	—
	20	66	32	32	17	15	38.5	9.6	9.6	—	—	7.4	8
	25	78	38	38	23	18	27.6	3.9	7.9	—	—	10	8
	30	84	42	42	22	19	37.4	10.4	13.4	—	—	11	10
	35	88	42	42	22	15	35	5	12	13	23	—	—
	45	100	51	51	20	20	32	7	17	15	29	—	—
	55	108	57	57	20	20	36	10	20	25	35	—	—
	65	132	75.5	75.5	28.5	25	46	9	9	28	42	—	—
	85	168	91	91	35.5	30	120	15	—	30	55	—	—
	100	198	100	100	43	33	152	13.3	—	36	60	—	—

Unit: mm

Model No.	Main dimensions						A ($\frac{L_{max}}{L_{min}}$)	Supported model numbers	
	Screw size S	Mounting bolt S ₁	a		b				
			A/C	R/V	A/C	R/V			
JSRG	15	M2	M4	7	7	4	10.5	5	15
	20	M2	M3	6.6	6.6	1.5	11	6	20
	25	M2	M3×6ℓ	-6.5	-2.5	4	15	6	25
	30	M3	M4×8ℓ	-5	-2	3	12	7	30
	35	M3	M4×4ℓ	0	7	6	-9	5	35
	45	M3	M5×4ℓ	0	10	10	-7	7	45
	55	M3	M5×4ℓ	3	13	16	-4	7	55
	65	M4	M6×5ℓ	3	3	19	-3	9	65
	85	M6	M6×8ℓ	3	—	23.5	—	9	85
	100	M6	M6×8ℓ	4	—	26	—	9	100

Example of model number coding JSRG35-60/420

1 Model number --- bellows for model SRG35

2 Bellows dimensions [length when compressed / length when extended]

Dedicated Bellows JSRG for Model SRG

13

Used in locations exposed to much dust or many cutting chips

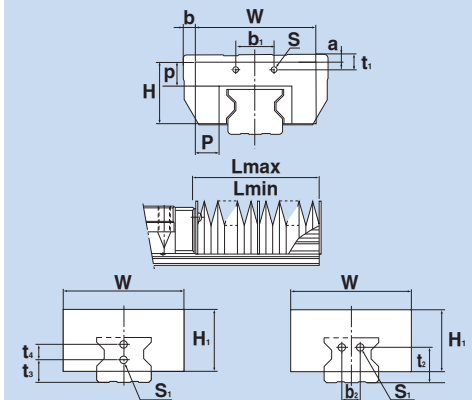

Models SRG15 to 30

Models SRG35 to 100

Note 1: When desiring to use the dedicated bellows other than in horizontal mount (i.e., vertical, wall and inverted mount), or when desiring a heatresistant type of bellows, contact THK.

Note 2: For lubrication when using the dedicated bellows, contact THK.

Note 3: When using the dedicated bellows, the LM block and LM rail need to be machined so that the bellows can be mounted. Be sure to indicate that the dedicated bellows are required when placing an order.

Note 4: In case of oil lubrication, be sure to let THK know the mounting orientation and the exact position in each LM block where the piping joint should be attached.

Note: The bellows length is calculated as follows.

$$L_{min} = \frac{S}{(A-1)} \quad S: \text{Stroke length (mm)}$$

$$L_{max} = L_{min} \cdot A \quad A: \text{Extension rate}$$

Lubrication Related Accessories

14 QZ Lubricator

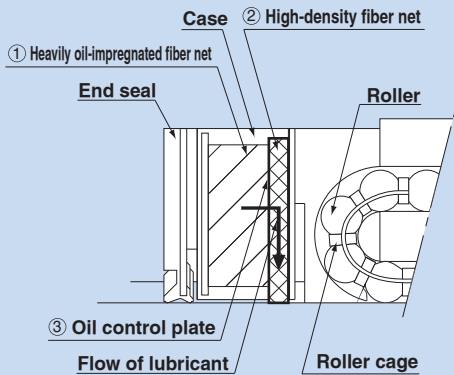

The structure of the QZ Lubricator consists of three major components:

- ① A heavy oil-impregnated fiber net (functions to store lubricant).
- ② A high-density fiber net (functions to apply lubricant to the raceway).
- ③ An oil-control plate (functions to control the flow of the lubricant).

The lubricant contained in the QZ Lubricator is fed to the LM system based on the principle of capillary action, which is used in felt-tip pens and other products.

14 QZ Lubricator™

The QZ Lubricator feeds a right amount of lubricant to the raceway of the LM rail. This allows an oil film to be constantly formed between the rolling elements and the ball raceway, thus significantly extending the lubrication maintenance interval.

When the QZ Lubricator is required, specify the desired type with the corresponding symbol indicated in Table 5.

For supported LM Guide models for the QZ Lubricator and the overall LM block length with the QZ Lubricator attached (dimension L), see Table 6.

Features

- Since it supplements an oil loss, the lubrication maintenance interval can significantly be extended.
- Since the right amount of lubricant is applied to the ball raceway, an environmentally friendly lubrication system that does not contaminate the surroundings is achieved.
- It allows the user to select a lubricant that meets the intended use.

Note 1: The QZ Lubricator is not sold alone.

Note 2: Those LM Guide models attached with the QZ Lubricator cannot have a grease nipple. When desiring both the QZ Lubricator and a grease nipple to be attached, contact THK.

Significantly Extended Maintenance Interval

Attaching the QZ Lubricator helps extend the maintenance interval throughout the whole load range from the light-load area to the heavy-load area.

Table 5 Parts Symbols for Model SRG with the QZ Lubricator Attached

Symbol	Contamination protection accessories with the QZ Lubricator attached
QZUU	End seal + QZ
QZSS	End seal + side seal + inner seal + QZ
QZDD	Double seals + side seal + inner seal + QZ
QZGG	LiCS + QZ
QZPP	LiCS + side seal + inner seal + QZ
QZZZ	End seal + side seal + inner seal + metal scraper + QZ
QZKK	Double seals + side seal + inner seal + metal scraper + QZ
QZSSH	End seal + side seal + inner seal + LaCS + QZ
QZDDHH	Double seals + side seal + inner seal + LaCS + QZ
QZZZHH	End seal + side seal + inner seal + metal scraper + LaCS + QZ
QZKKHH	Double seals + side seal + inner seal + metal scraper + LaCS + QZ
QZJJHH	With end seal + side seal + inner seal + LaCS + QZ + protector (serving also as metal scraper)
QZTTHH	With double seals + side seal + inner seal + LaCS + QZ + protector (serving also as metal scraper)

Note: Light Sliding Resistance Contact Seal LiCS (QZGG and QZPP) is available only for model SRG 15.

Table 6 Overall LM Block Length (Dimension L) of Model SRG/SRN with the QZ Lubricator Attached

Unit: mm

Model No.	L										
	QZUU	QZSS	QZDD	QZZZ	QZKK	QZSSH	QZDDHH	QZZZHH	QZKKHH	QZJJHH	QZTTHH
SRG	15A/V	90.6	90.6	92.6	—	—	—	—	—	—	—
	20A/V	107.6	107.6	109.6	111	113	125.2	127.2	127.6	129.6	—
	20LA/LV	127.6	127.6	129.6	131	133	145.2	147.2	147.6	149.6	—
	25C/R	125.5	125.5	130.5	130.5	135.5	145.3	151.7	147.7	154.1	—
	25LC/LR	145.1	145.1	150.1	150.1	155.1	164.9	171.3	167.3	173.7	—
	30C/R	141	141	148	146	153	160.8	169.2	164.6	171.6	—
	30LC/LR	165	165	172	170	177	184.8	193.2	188.6	195.6	—
	35C/R	155	155	162.8	163.4	171.2	172.6	180.4	181	188.8	180.8
	35LC/LR	185	185	192.8	193.4	201.2	202.6	210.4	211	218.8	210.8
	35SLC/SLR	210.8	210.8	218.6	219.2	227	228.4	236.2	236.8	244.6	236.6
	45C/R	185	185	194.2	194.2	203.4	205.6	214.8	214.8	224	214.6
	45LC/LR	220	220	229.2	229.2	238.4	240.6	249.8	249.8	259	249.6
	45SLC/SLR	261.5	261.5	270.7	270.7	279.9	282.1	291.3	291.3	300.5	291.1
	55C/R	225	225	234.2	234.2	243.4	245.6	254.8	254.8	264	254.6
	55LC/LR	275	275	284.2	284.2	293.4	295.6	304.8	304.8	314	304.6
	55SLC/SLR	332	332	341.2	341.2	350.4	352.6	361.8	361.8	371	361.6
	65C/V	284.9	284.9	296.1	296.1	307.3	308.9	320.1	320.1	331.3	319.9
	65LC/LV	343	343	354.2	354.2	365.4	367	378.2	378.2	389.4	378
	65LC/SLV	420	420	431.2	431.2	442.4	444	455.2	455.2	466.4	455

Unit: mm

Model No.	L											
	QZUU	QZSS	QZDD	QZZZ	QZKK	QZSSH	QZDDH	QZZZH	QZKKH	QZJH	QZTTH	
SRN	35C/R	155	155	162.8	163.4	171.2	178.6	186.4	181	188.8	—	—
	35LC/LR	185	185	192.8	193.4	201.2	208.6	216.4	211	218.8	—	—
	45C/R	185	185	194.2	194.2	203.4	212	221.2	215.2	224.5	—	—
	45LC/LR	220	220	229.2	229.2	238.4	247	256.2	250.2	259.4	—	—
	55C/R	225	225	234.2	234.2	243.4	252	261.2	255.2	264.4	—	—
	55LC/LR	275	275	284.2	284.2	293.4	302	311.2	305.2	314.4	—	—
65LC/LR	343	343	354.2	354.2	370.4	380.4	391.6	378.6	389.8	—	—	

* The overall LM block length (L) of YY type (with side scraper) is also the same.

15 Greasing Hole

Models SRG/SRN allow lubrication from both the side and top faces of the LM block. The greasing hole of standard types is not drilled through in order to prevent foreign material from entering the LM block. When using the greasing hole, contact THK.

The greasing interval is longer than full-roller type LM Guides thanks to the roller cage effect. However, the greasing interval varies according to the service environment such as a heavy load and high speeds. Contact THK for details.

Unit: mm

Model No.	Pilot hole for side nipple			Applicable nipple	Greasing hole on the top face						
	e ₀	f ₀	D ₀		D ₂	(O-ring)	V	e ₁	d ₂		
SRG	15A 15V	4	6	2.9	PB107	9.2	(P6)	0.5	5.5	1.5	
	20A 20LA	4	6	2.9	PB107	9.2	(P6)	0.5	6.5	1.5	
	20V 20LV	4	6	2.9	PB107	9.2	(P6)	0.5	6.5	1.5	
	25C 25LC	6	6.4	5.2	M6F	10.2	(P7)	0.5	6	1.5	
	25R 25LR	6	10.4	5.2	M6F	10.2	(P7)	4.5	6	1.5	
	30C 30LC	6	7.5	5.2	M6F	10.2	(P7)	0.4	6	1.4	
	30R 30LR	6	10.5	5.2	M6F	10.2	(P7)	3.4	6	1.4	
	35C 35LC 35SLC	6	6	5.2	M6F	10.2	(P7)	0.4	6	1.4	
	35R 35LR 35SLR	6	13	5.2	M6F	10.2	(P7)	7.4	6	1.4	
	45C 45LC 45SLC	7	7	5.2	M6F	10.2	(P7)	0.4	7	1.4	
	45R 45LR 45SLR	7	17	5.2	M6F	10.2	(P7)	10.4	7	1.4	
	55C 55LC 55SLC	9	8.5	5.2	M6F	10.2	(P7)	0.4	11	1.4	
	55R 55LR 55SLR	9	18.5	5.2	M6F	10.2	(P7)	10.4	11	1.4	
	65C 65LC 65SLC	9	13.5	5.2	M6F	10.2	(P7)	0.4	10	1.4	
	65V 65LV 65SLV	9	13.5	5.2	M6F	10.2	(P7)	0.4	10	1.4	
	85LC	15	22	8.2	B-R1/8 (B-PT1/8)	13	(P10)	0.4	10	1	
	100LC	15	23	8.2	B-R1/8 (B-PT1/8)	13	(P10)	0.4	10	1	
	SRN	35C 35LC	8	7	5.2	M6F	10.2	(P7)	0.4	6	1
		35R 35LR	8	7	5.2	M6F	10.2	(P7)	0.4	6	1
		45C 45LC	8.5	7.6	5.2	M6F	10.2	(P7)	0.4	7	1
45R 45LR		8.5	7.6	5.2	M6F	10.2	(P7)	0.4	7	1	
55C 55LC		10	9.8	5.2	M6F	10.2	(P7)	0.4	11	1	
55R 55LR		10	9.8	5.2	M6F	10.2	(P7)	0.4	11	1	
65LC		9	13	5.2	M6F	10.2	(P7)	0.4	10	1	
65LR		9	13	5.2	M6F	10.2	(P7)	0.4	10	1	

Note: When using the greasing hole on the top face of models SRG-R and SRG-LR, a greasing adapter is separately required. Contact THK for details.

Greasing hole

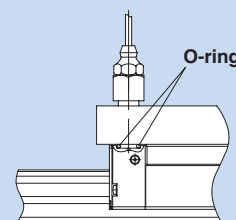
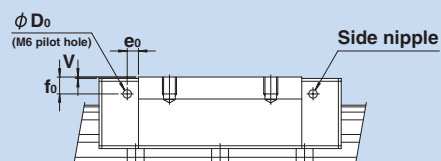
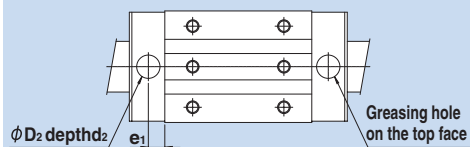

Method for using the greasing hole on the top face

●Precautions on Using the LM Guide

[Handling]

- (1) Most models of this product are heavy articles (20 kg or heavier). Please use at least two people to move any heavy object, or use a dolly or another conveyance. Otherwise, it may cause injury or damage the unit.
- (2) Do not disassemble the parts. Otherwise, it may reduce the functionality.
- (3) Tilting an LM block or LM rail may cause them to fall by their own weight.
- (4) Take care not to drop or strike the LM Guide. Otherwise, it may cause injury or damage the unit. If the product is dropped or impacted, functionality may be reduced even if there is no surface damage.
- (5) Do not remove the LM block from the LM rail during setup.
- (6) Do not insert fingers into the mounting holes on the LM rail, as they could get caught between the rail and the LM block, resulting in injury.
- (7) To ensure personal safety, wear gloves and protective footwear when handling this product.

[Precautions on Use]

- (1) Prevent foreign material, such as cutting chips or coolant, from entering the product. This may also cause damage to the product.
- (2) If the product is used in an environment where cutting chips, coolant, corrosive solvents, water, etc., may enter the product, use bellows, covers, etc., to prevent them from entering the product.
- (3) Do not use the product at temperature of 80°C or higher. Unless the unit is specially designed to be heat-resistant, exposure to such temperatures may deform or damage plastic and rubber parts.
- (4) In the event that cutting chips or other foreign material adheres to the unit, clean it off and reapply lubricant.
- (5) Micro-strokes can inhibit the formation of a film of oil between the raceways and the ball, resulting in fretting. So use grease with high fretting resistance. THK recommends periodically making stroke movement of about the length of the LM block to help ensure that a film forms on the raceways and balls.
- (6) Do not forcibly drive a pin, key, or other positioning device into this product. This may generate indentations on the raceway, leading to loss of functionality.
- (7) If, for operational reasons, it becomes absolutely necessary to remove the LM block from the LM rail and reattach it, a special mounting jig must be used for this purpose. (The removing/mounting jig is not provided as standard. When desiring to use it, contact THK.)
- (8) Position the mounting jig so that one end abuts the end of the LM rail. When the rail and the jig are exactly aligned, the LM block can be loaded onto the rail.
- (9) Take care to keep the LM block straight. Loading the block at an angle can introduce foreign material, damage internal components, or cause balls to fall out.
- (10) The LM block must contain all its internal rolling elements (balls) when mounted on the LM rail. Using a block with any balls removed may result in premature damage.
- (11) If any of the balls falls from the LM block, contact THK instead of using the product.
- (12) If the endplate is damaged due to an accident, etc., balls may fall out or the LM block may become detached from the LM rail and drop. If the LM Guide will be used hanging upside down, take preventive measures such as adding a safety mechanism to prevent falls.
- (13) If the durability of the mounting parts are insufficient and the mounting accuracy is bad, an unexpected load will be applied to the LM block, which may cause damage at an early stage. Accordingly, give sufficient consideration to the rigidity/accuracy of the housing and base.
- (14) When removing the LM block from the LM rail and then replacing the block, an LM block mounting/removing jig that facilitates such installation is available. Contact THK for details.

[Lubrication]

- (1) Thoroughly wipe off anti-rust oil and feed lubricant before using the product.
- (2) Do not use a mix of different lubricants. Mixing greases using the same type of thickening agent may still cause adverse interaction between the two greases if they use different additives, etc.
- (3) When using the product in locations exposed to constant vibrations or in special environments such as clean rooms, vacuum and low/high temperature, use the grease appropriate for the specification/environment.
- (4) To lubricate a product that has no grease nipple or oil hole, apply lubricant directly to the raceway surface and execute a few preliminary strokes to ensure that the interior is fully lubricated.
- (5) Lubricant viscosity can vary depending on the temperature. Take note that the slide resistance and torque of the LM Guide also changes as the consistency of grease changes.
- (6) After lubrication, the slide resistance and torque of the LM Guide may increase due to the agitation resistance of grease. Be sure to perform a break-in to let the grease spread fully, before operating the machine.
- (7) Excess lubricant may spatter immediately after lubrication. If necessary, wipe off any spattered grease.
- (8) Lubricant performance declines over time. It is needed to lubricate when needed, depending on how frequently the machine is operated.
- (9) Although the lubrication interval may vary according to use conditions and the service environment, lubrication should be performed approximately every 100 km in travel distance (three to six months). Set the final lubrication interval/amount based on the actual machine.
- (10) If the installation direction is other than horizontal use, the lubricant may not reach the raceway completely.
- (11) When adopting oil lubrication, the lubricant may not be distributed throughout the LM block depending on the installation direction of the block. Contact THK in advance for details.

[Storage]

When storing the LM Guide, enclose it in a package designated by THK and store it in a room in a horizontal orientation while avoiding high temperature, low temperature and high humidity.
After the product has been in storage for an extended period of time, lubricant inside may have deteriorated, so add new lubricant before use.

[Disposal]

Dispose of the product properly as industrial waste.

Lubricator QZ

[Precaution on Selection]

Secure a stroke longer than the overall LM block with Lubricator QZ attached.

[Handling]

Take care not to drop or strike this product. Otherwise, it may cause injury or damage the unit.

Keep air holes clear of grease or other obstructions.

The Lubricator QZ lubricates the raceway only, so it must be used in combination with regular greasing or lubrication.

If the product is used in an environment exposed to coolant, cutting chips or other foreign material, oil on the raceway is lost easily. Accordingly, be sure to also use covers, bellows, etc.

[Service environment]

Be sure the service temperature of this product is between -10 to 50°C, and do not clean the product by immersing it in an organic solvent or white kerosene, or leave it unpacked.

Laminated Contact Scraper LaCS

[Handling]

The lubricant impregnated into the scraper is used to increase its sliding capability. For lubrication of the LM Guide, attach Lubricator QZ, or the grease nipple on the LM block, before providing a lubricant.

When using the product, be sure to attach the rail cap C/GC or the steel tape.

[Service environment]

Be sure the service temperature of this product is between -20 to +80°C, and do not clean the product by immersing it in an organic solvent or white kerosene, or leave it unpacked.

[Notes on the Product Functions]

It is specifically designed to provide dust prevention capability to remove foreign material and liquid. To seal oil, an end seal is required.

Cap GC

[Handling]

If GC caps are specified for the product, the edges of the LM rail mounting hole openings will be sharp. Take great care not to injure your fingers or hands while working.

When fitting GC caps, use a flat aligning tool to gradually punch the cap into the hole until it is level with the upper surface of the LM rail. Then run an oilstone over the rail until the upper surface of the rail and the GC caps are completely flat.

LIMITED WARRANTY

LIMITED WARRANTY AND LIMITATION OF LIABILITY: THK CO. LTD., FOR ITSELF AND ITS RELATED COMPANIES AND SUBSIDIARIES (HEREINAFTER DESCRIBED COLLECTIVELY AS "THK") WARRANTS THAT ALL THK PRODUCTS SOLD WILL BE FREE OF DEFECTS IN MATERIALS AND WORKMANSHIP FOR A PERIOD OF TWELVE (12) MONTHS FROM DATE OF DELIVERY. THE FOREGOING TWELVE (12) MONTH WARRANTY SHALL NOT BE EXTENDED OR CHANGED BY THK FURNISHING ANY REPLACEMENTS, ADDITIONS, ATTACHMENTS, ACCESSORIES OR REPAIRS TO THE PRODUCT SUBSEQUENT TO THE DATE OF DELIVERY OR ACCEPTANCE. THE FOREGOING WARRANTY IS THE SOLE AND EXCLUSIVE WARRANTY OF THK REGARDING THE PRODUCT.

DISCLAIMER OF OTHER WARRANTIES: OTHER THAN THE FOREGOING WARRANTY, THERE ARE NO EXPRESS OR IMPLIED WARRANTIES OR ANY AFFIRMATIONS OF FACT OR PROMISES BY THK WITH RESPECT TO THE PRODUCT. THK DISCLAIMS ANY WARRANTIES, EXPRESS, IMPLIED OR STATUTORY, NOT SPECIFICALLY SET FORTH ABOVE. WITHOUT LIMITING THE GENERALITY OF THE FOREGOING, THK EXPRESSLY DISCLAIMS ANY IMPLIED WARRANTIES OF MERCHANTABILITY, FITNESS FOR ANY PARTICULAR PURPOSE, INFRINGEMENT OR ANY REPRESENTATIONS OF FACT OR QUALITY NOT EXPRESSLY SET FORTH HEREIN.

LIMITATION OF LIABILITY AND REMEDIES: THK'S SOLE RESPONSIBILITY AND LIABILITY INCURRED AS A RESULT OF THE SALE AND/OR USE OF THE PRODUCT, AND THE PURCHASER'S EXCLUSIVE REMEDY AGAINST THK UNDER ANY WARRANTY SHALL BE LIMITED TO THE REPAIR OR REPLACEMENT, AT THK'S OPTION, OF PRODUCT COMPONENTS NOT CONFORMING TO THE WARRANTY. THE TOTAL LIABILITY OF THK SHALL IN NO EVENT EXCEED THE AMOUNT ACTUALLY PAID TO THK BY PURCHASER WITH RESPECT TO THE PRODUCT. THIS LIMITATION OF REMEDY IS INTENDED BY THE PARTIES TO SURVIVE EVEN IF THE REMEDY IS CLAIMED TO HAVE FAILED OF ITS ESSENTIAL PURPOSE. PURCHASER'S FULL AND COMPLETE PERFORMANCE OF ALL OBLIGATIONS OF PURCHASER RECITED IN THIS AGREEMENT IS A CONDITION PRECEDENT TO THK'S WARRANTY OBLIGATIONS AND LIABILITIES HEREIN.

PURCHASER'S DAMAGES AND LIMITATIONS: IN NO EVENT SHALL THK BE LIABLE TO PURCHASER, ITS ASSIGNS OR AGENTS, FOR ECONOMIC LOSS, INCIDENTAL OR CONSEQUENTIAL DAMAGES, IN CONTRACT OR IN TORT, INCLUDING BUT NOT LIMITED TO, ANY DAMAGES FOR LOST PROFITS, DOWN-TIME, LOST PRODUCTION, FAILURE TO MEET PURCHASER'S SALES CONTRACTS, OR DEFECTS IN PURCHASER'S MATERIALS OR WORKMANSHIP ARISING DIRECTLY OR INDIRECTLY FROM THE USE OF THE PRODUCT.

DISCLAIMER

This Catalog provides basic information relating to THK linear motion and related products. The Catalog, including all information, charts, formulas, factors, accuracy standards, tolerances and application recommendations contained herein, is only a starting point for the customer's selection of appropriate products, and may not apply in all intended applications. The Catalog is not a substitute for a proper application analysis conducted by an experienced, knowledgeable design engineer. Product selection should be based upon your specific application needs and conditions, which will vary greatly depending on many factors. No specific product application should be based solely on the information contained in this Catalog. All purchases of THK Products are subject to the limited warranty offered by THK Co., Ltd, for itself and on behalf of its related companies and subsidiaries. Customers should confirm independently that a contemplated application is safe, appropriate and effective.

"All trademarks used in this Catalog are registered trademarks in the Country of Japan. If there is any question as to the validity of such trademarks outside of Japan, an inquiry should be made in that particular country."

Technical Support Site

The THK Technical Support Site lets you access product information and technical support online. You will also find a search feature for locating desired products and a calculation feature for calculating service life. 2D-CAD and 3D-CAD data are also downloadable.



Product Information

CAD Data

Technical Calculation

Technical Information

Catalog Information

FAQ

<https://tech.thk.com/> or

- “LM GUIDE,” and “” are registered trademarks of THK CO., LTD.
 - The photo may differ slightly in appearance from the actual product.
 - The appearance and specifications of the product are subject to change without notice. Contact THK before placing an order.
 - Although great care has been taken in the production of this catalog, THK will not take any responsibility for damage resulting from typographical errors or omissions.
 - For the export of our products or technologies and for the sale for exports, THK in principle complies with the foreign exchange law and the Foreign Exchange and Foreign Trade Control Law as well as other relevant laws.
For export of THK products as single items, contact THK in advance.
- All rights reserved

THK CO., LTD.

Head Office 3-11-6 Nishigotanda, Shinagawa-ku, Tokyo 141-8503 JAPAN
International Sales Department Phone:+81-3-5434-0351 Fax:+81-3-5434-0353

Global site : <http://www.thk.com/>

EUROPE

- THK GmbH
- EUROPEAN HEADQUARTERS
Phone:+49-2102-7425-555 Fax:+49-2102-7425-556
 - DÜSSELDORF OFFICE
Phone:+49-2102-7425-0 Fax:+49-2102-7425-299
 - STUTTGART OFFICE
Phone:+49-7141-4988-500 Fax:+49-7141-4988-888
 - U.K. OFFICE
Phone:+44-1384-47-1550 Fax:+44-1384-47-1551
 - ITALY OFFICE
Phone:+39-02-9901-1801 Fax:+39-02-9901-1881
 - SWEDEN OFFICE
Phone:+46-8-445-7630 Fax:+46-8-445-7639
 - AUSTRIA OFFICE
Phone:+43-7229-51400 Fax:+43-7229-51400-79
 - SPAIN OFFICE
Phone:+34-93-652-5740 Fax:+34-93-652-5746
 - TURKEY OFFICE
Phone:+90-216-362-4050 Fax:+90-216-569-7150
 - PRAGUE OFFICE
Phone:+420-2-41025-100 Fax:+420-2-41025-199
 - MOSCOW OFFICE
Phone:+7-495-649-80-47 Fax:+7-495-649-80-44
- THK Europe B.V.
- EINDHOVEN OFFICE
Phone:+31-040-290-9500 Fax:+31-040-290-9599
 - THK France S.A.S.
 - PARIS OFFICE
Phone:+33-1-7425-3800 Fax:+33-1-7425-3799

NORTH AMERICA

- THK America, Inc.
- HEADQUARTERS
Phone:+1-847-310-1111 Fax:+1-847-310-1271
 - CHICAGO OFFICE
Phone:+1-847-310-1111 Fax:+1-847-310-1182

- NORTH EAST OFFICE
Phone:+1-631-244-1565 Fax:+1-631-244-1565
- ATLANTA OFFICE
Phone:+1-770-840-7990 Fax:+1-770-840-7897
- LOS ANGELES OFFICE
Phone:+1-949-955-3145 Fax:+1-949-955-3149
- SAN FRANCISCO OFFICE
Phone:+1-925-455-8948 Fax:+1-925-455-8965
- DETROIT OFFICE
Phone:+1-248-858-9330 Fax:+1-248-858-9455
- TORONTO OFFICE
Phone:+1-905-820-7800 Fax:+1-905-820-7811

SOUTH AMERICA

- THK BRAZIL INDUSTRIA E COMERCIO LTDA.
Phone:+55-11-3767-0100 Fax:+55-11-3767-0101

CHINA

- THK (CHINA) CO., LTD.
- HEADQUARTERS
Phone:+86-411-8733-7111 Fax:+86-411-8733-7000
 - SHANGHAI OFFICE
Phone:+86-21-6219-3000 Fax:+86-21-6219-9890
 - BEIJING OFFICE
Phone:+86-10-8441-7277 Fax:+86-10-6590-3557
 - CHENGDU OFFICE
Phone:+86-28-8526-8025 Fax:+86-28-8525-6357
 - GUANGZHOU OFFICE
Phone:+86-20-8523-8418 Fax:+86-20-3801-0456
 - SHENZHEN OFFICE
Phone:+86-755-2642-9587 Fax:+86-755-2642-9604
 - XIAN OFFICE
Phone:+86-29-8834-1712 Fax:+86-29-8834-1710
- THK (SHANGHAI) CO., LTD.
Phone:+86-21-6275-5280 Fax:+86-21-6219-9890

TAIWAN

- THK TAIWAN CO., LTD.
- TAIPEI HEAD OFFICE
Phone:+886-2-2888-3818 Fax:+886-2-2888-3819
 - TAICHUNG OFFICE
Phone:+886-4-2359-1505 Fax:+886-4-2359-1506
 - TAINAN OFFICE
Phone:+886-6-289-7668 Fax:+886-6-289-7669

KOREA

- SEOUL REPRESENTATIVE OFFICE
Phone:+82-2-3468-4351 Fax:+82-2-3468-4353

SINGAPORE

- THK LM System Pte. Ltd.
Phone:+65-6884-5500 Fax:+65-6884-5550

THAILAND

- THK RHYTHM (THAILAND) CO., LTD. LM System Division
- Bangkok Branch
Phone:+66-2751-3001 Fax:+66-2751-3003

INDIA

- THK India Pvt. Ltd.
- HEADQUARTERS & Bangalore Branch
Phone:+91-80-2340-9934 Fax:+91-80-2340-9937
 - Pune Branch
Phone:+91-20-4120-8742
 - Chennai Branch
Phone:+91-44-4042-3132
 - Ahmedabad Branch
Phone:+91-79-6134-4925
 - Delhi Branch
Phone:+91-12-4676-8695